

# Worcestershire Federation of Young Farmers County Show



**25<sup>th</sup> May 2019**

By kind permission of Mr Hodgetts  
Park Farm, Kerswell Green, Worcester,  
WR5 3PD



## Table of Contents

Comp No.	Competition	Theme (if relevant)
-	<a href="#"><u>County Show Day Rules</u></a>	
1	<a href="#"><u>Club Show Support Points</u></a>	N/A
2	<a href="#"><u>Show Advertisement Board</u></a>	County Show
3	<a href="#"><u>Defford Advertising Banner</u></a>	Defford Doo
4	<a href="#"><u>Main Exhibit</u></a>	Great British Holidays
5	<a href="#"><u>Junior Exhibit</u></a>	Holidays
6	<a href="#"><u>Cube</u></a>	Children's Television
7	<a href="#"><u>YFC Showcase</u></a>	Our Young Farmers' County
8	<a href="#"><u>Photography – Senior</u></a>	Life by the Beach
9	<a href="#"><u>Photography – Intermediate</u></a>	Topping up the Tan
10	<a href="#"><u>Photography – Junior</u></a>	Guess Which Holiday
11	<a href="#"><u>Craft – Senior</u></a>	Holiday Resort Diorama
12	<a href="#"><u>Craft – Intermediate</u></a>	Deck Chair
13	<a href="#"><u>Craft - Junior</u></a>	Festival Head Gear
14	<a href="#"><u>Metalwork</u></a>	Sundial (Free Standing)
15	<a href="#"><u>YFC Bake Off - Senior</u></a>	Picnic Basket
16	<a href="#"><u>YFC Bake Off - Intermediate</u></a>	Caravan Carrot Cake
17	<a href="#"><u>YFC Bake Off – Junior</u></a>	Sea Shell Biscuits
18	<a href="#"><u>Needlework Great British Sewing Bee</u></a>	Picnic Blanket
19 & 20	<a href="#"><u>Sheep Shearing – Senior &amp; Intermediate</u></a>	-
21	<a href="#"><u>Floral Art – Senior</u></a>	Great Inventions That Changed The World
22	<a href="#"><u>Floral Art – Intermediate</u></a>	Great Craftsmanship
23	<a href="#"><u>Floral Art – Junior</u></a>	My Great Hobby
24	<a href="#"><u>Cookery – Boys</u></a>	Honeymoon Brunch
25	<a href="#"><u>Woodwork</u></a>	Bird Table
26	<a href="#"><u>Auctioneering</u></a>	
27	<a href="#"><u>Cookery – Intermediate</u></a>	Rare Breeds Survival Trust Gala Dinner (Main)
28	<a href="#"><u>Obstacle Race on Skis</u></a>	
29	<a href="#"><u>Highland Fling</u></a>	

30	<a href="#"><u>Cookery – Senior</u></a>	Rare Breeds Survival Trust Gala Dinner (Starter)
31	<a href="#"><u>Holiday Rep Variety Performance</u></a>	
32- 36	See Stock-judging Rule Book	
37	<a href="#"><u>Cookery - Junior</u></a>	Rare Breeds Survival Trust Gala Dinner (Dessert)
38	<a href="#"><u>Parody Song</u></a>	
39	<a href="#"><u>Soapbox Race</u></a>	
Comp No. 40- 45	<a href="#"><u>Tug of War – Mixed Juniors</u></a> <a href="#"><u>Tug of War – Ladies</u></a> <a href="#"><u>Tug of War - Men's</u></a>	Weigh in  Weigh in Weigh in
46	<a href="#"><u>Cake Decorating – Intermediate</u></a>	Easter Cake
47	<a href="#"><u>YFC's Got Talent</u></a>	
48	<a href="#"><u>Cake Decorating – Junior</u></a>	Under The Sea
49	<a href="#"><u>Haka</u></a>	
50	<a href="#"><u>Cake Decorating – Senior</u></a>	Life on the Slopes
51	<a href="#"><u>Sand Castle Building</u></a>	
52	<a href="#"><u>Chairman's Challenge</u></a>	
53	<a href="#"><u>Poultry Boning &amp; Jointing</u></a>	
54	<a href="#"><u>Carnival Dance</u></a>	

## Competition Entry Timetable & Rules

### Competition Dates:

Live Stock Judging  
Carcase  
Show Day

**Saturday 11<sup>th</sup> & Sunday 12<sup>th</sup> May 2019**  
**Sunday 3<sup>rd</sup> March 2019**  
**Saturday 25<sup>th</sup> May 2019**

### Age Limits:

- Senior - Competitors must be 26 years of age or under on 1st September 2018
- Intermediate - Competitors must be 21 years of age or under on 1st September 2018
- Junior - Competitors must be 16 years of age or under on 1st September 2018, but over 10 years of age.

Where Clubs are allowed more than one entry in Junior Competitions, only the top-scoring mark will count towards any relevant Show cups.

### Competition Entry Closing Dates – These will be strictly adhered to:

**For the Carcase Judging & Stock Judging competitions** forms must be received in County Office by **8pm on Monday 25<sup>th</sup> February 2019**

**For County Show Day competitions** forms must be received in County Office by **8pm hrs on Monday 6<sup>th</sup> May 2019. Telephone entries will not be accepted**

### Membership Application Closing Dates – These will be strictly adhered to:

Membership application form and full payment must be received by County Office no later than the below times in order for the competitor to be eligible to compete.

Carcase & Stockjudging **Monday 25<sup>th</sup> February 2019 8pm**  
Show Day Competitions **Monday 6<sup>th</sup> May 2019 8pm**

**Note:** The Committee reserves the right to penalise or disqualify any Club or Competitor who infringes any of the rules.

## SHOW TIMINGS

Please refer to the timetable of the day - for the Show to run smoothly, this timetable must be adhered to. **Each Competitor must report to the Steward 15 minutes before the start time of the Competition.**

**Reminder:** Failure to report or removal of any materials as part of a displayed competition before 5.00pm or any time announced by the Chief Steward may result in disqualification.

## ENTRANCE FEES

- £1 entry to Worcestershire card carrying members all day
- £5 everyone else (under 10s free of charge).

## HEALTH & SAFETY CONSIDERATIONS

Worcestershire Federation of Young Farmers' Clubs [WFYFC] want everyone to enjoy the competitions on Show Day and to compete in as safe a manner as is possible.

In order to achieve this we rely on everyone to be aware of Health & Safety considerations attached to staging a County Show. Please be responsible for your own actions and the safety of those around you and report anything amiss to the Show Office in the first instance to allow the appropriate action to be taken.

**All competitors are informed that alcohol is a big factor in accidents, and competitors are expected not to drink alcohol before or during any of the competitions. Anyone who is thought to have consumed any alcohol prior to starting any competition will be disqualified at the discretion of the Judge or Chief Steward for all of the day's competitions. There may be no appeal.**

**NO BBQ's will be allowed to set up in the car park and NO alcohol can be consumed in the car park either.**

*All clubs have a duty of care to their members and others, and therefore should ensure that the competitors they are entering for any competition are suitably knowledgeable, trained, capable and equipped to safely participate in that specific competition so as not to cause any harm to themselves or others through their actions. WFYFC will prohibit any competitor from entering or continuing a competition if they feel the competitor is not competent.*

## General Show Rules

1. Competitors must arrive on time and report to the competition steward 15 minutes before the published competition start time with all relevant equipment, e.g. white coats and a valid membership card.
2. **Any member failing to produce a valid membership card will be able to purchase a temporary membership card, at a cost of £5.00, which will only be valid for the Show Day. Disco tickets cannot be purchased with a temporary membership card.**

**Please note:** Failure to have a valid membership card (either official or temporary) in any competition will result in the member being unable to compete.
3. All Clubs have a duty of care to their members and others, and therefore should ensure that the competitors they are entering for any competition are suitably knowledgeable, trained, capable and equipped to safely participate in that specific competition so as not to cause any harm to themselves or other through their actions. WFYFC will prohibit any competitor from entering or continuing a competition if they feel the competitor is not competent.
4. In the case of ATV Challenge, Four Wheel Drive & Maintenance and Tractor Handling & Maintenance if a member fails to produce a valid membership card together with his/her current driving or tractor licence, they will not be allowed to compete. **ATV Challenge competitors also require a valid Certificate of Competence.**
5. **No alcohol is to be consumed by competitors before entering or during competitions. Competitors will be disqualified from the competition for infringement of this rule.**
6. Competitors must only communicate with their fellow competitors, Judges and Stewards where necessary. Any competitor found to be in communication with anyone else is liable for disqualification.
7. No Club names or items that may distinguish which club exhibits belong to be displayed unless stated otherwise in the rules.
8. Competitors must not communicate directly or indirectly with any person other than Judges and stewards under penalty of disqualification. STRICTLY NO MOBILE PHONES.
9. Rules subject to change without notification – check [www.worcsyfc.org.uk/showrules](http://www.worcsyfc.org.uk/showrules) for the latest release. The Chief Steward reserves the right to alter any rule if deemed necessary.
10. No competitor may compete in more than ONE category of a competition, i.e. Junior/Intermediate/Senior.
11. Any Club not satisfied with the way a competition has been run has one hour after the end of the competition to lodge an official written complaint with the Show Office.
12. WFYFC reserve the right to cancel any livestock class as a reasonable precaution in line with any current prevalent infections/viruses.
13. Valuable items are the responsibility of the owner/exhibitor. WFYFC accepts no responsibility for any item lost or stolen whilst on the showground or related events.
14. All articles to have been produced within the past 12 months unless otherwise stated in Competition Rules.
15. In case of dispute the Chief Steward's decision is final. The Chief Steward is Mr Peter Rose.
16. Any gross infringement of the rules may result in a penalty to the Clubs results.
17. No exhibits in any competition may be removed before the end of the presentation of awards, unless otherwise directed by the Chief Steward. Failure to comply will result in all marks awarded for the competition concerned being removed.
18. **No bottles of alcohol to be put on display – use bottles of coloured water if necessary.**
19. **No BBQs will be allowed to set up in the car park and NO alcohol can be consumed in the car park either.**
20. **The Committee reserves the right to penalise or disqualify any Club or Competitor who infringes any of the rules.**
21. **Any members under 18 years of age on the competition day must complete a signed parental consent form. This is to be handed into the Show Office on the morning of the show. The Parental Consent form will be checked and exchanged for a coloured wristband that the competitor MUST wear. Stewards are to check that any members that are Under 18 are wearing a wristband before the start of the competition. If a Parental Consent is not handed into the Show Office for a member that is Under 18 they will not be able to compete in the Show.**





## Show Trophies

<b>Show Championship Cup</b>	(presented by Captain J F Bomford) Awarded to the Club gaining the highest marks in all Show competitions, including all the Junior Competitions, and including all Afternoon Events but excluding Tug of War.
<b>Junior Events Cup</b>	Awarded to the Club gaining the highest marks in Junior Competitions, including any Junior Afternoon Events.
<b>The Jubilee Cup</b>	(presented by Mrs Margaret Herbert) Awarded to the club gaining the highest marks in the Senior and Intermediate competitions including Four Wheel Drive & Maintenance and Carcase Judging.
<b>Venables Shield</b>	(presented by the late J T Venables Esq.) Awarded to the Club gaining the highest marks in the following craft competitions: Cookery; Floral Art; Cake Decoration; Bake-off; Woodwork; Metalwork; Craft and live craft; and Needlework. Poultry Boning and Jointing
<b>Afternoon Events Cup</b>	(presented by Mr Frank Gill) Awarded to the Club gaining the highest marks in the Afternoon Events Programme.
<b>Stockjudging Cup</b>	(presented by Alderman T S Bennett) Awarded to the Club gaining the highest marks in Dairy, Beef, Sheep, Pig & Horse Judging competitions.
<b>The Howell Refrigeration Trophy</b>	(presented by Howell Refrigeration) Awarded to the Club gaining the highest marks in the Dairy Judging competition (Senior & Intermediate).
<b>Horse Judging Cup</b>	(presented by L R Jackman, Esq.) Awarded to the Club gaining the highest marks in the Horse Judging competition (Senior & Intermediate).
<b>The Brindley Richards Sheep Judging Cup</b>	(presented by Mr & Mrs C V Richards) Awarded to the Club gaining the highest marks in the Sheep Judging competition (Senior & Intermediate)
<b>The Gordon Tyler Cup</b>	(presented by Mr Gordon Tyler) Awarded to the individual gaining the highest marks in Junior Sheep Judging competition
<b>The Team Sheep Shearing Cup</b>	(Presented by Mr T Murray Watson). Awarded to the Club gaining the highest marks in the Sheep Shearing competition.
<b>Poultry Cup</b>	(presented by Messrs J P Harvey Limited) Awarded to the Club gaining the highest marks in the Poultry Boning & Jointing competition (Senior & Intermediate).
<b>Main Exhibit Cup</b>	(presented by the British Sugar Corporation) Awarded to the Club gaining the highest marks in the Main Exhibit competition.
<b>Amoco Tractor Handling Tankard</b>	(presented by AMOCO Limited) Awarded to the individual gaining the highest marks in the Tractor Handling & Maintenance competition
<b>The Will Davies Trophy</b>	(presented by Mr Will Davies) Awarded to the individual gaining the highest marks in the Metalwork competition.
<b>The Woodwork Tankard</b>	Awarded to the Club gaining the highest marks in the Woodwork competition.
<b>The Mary Talbot Award</b>	Awarded to an individual for the most outstanding floral display.
<b>The Hugh Sumner Rosebowl</b>	Awarded for the Champion Beef Calf.
<b>The K J Fellows Cup</b>	Awarded for the Best Beef Calf show by a Member under 18.
<b>The Morgan Cup</b>	(presented by H W Morgan) Awarded for the Champion Dairy Heifer Calf.
<b>The BOCM Tankard</b>	Awarded for the Best Dairy Calf shown by a member under 18.
<b>The Jim Rawles Memorial Trophy</b>	Awarded for the team gaining the highest marks in the Men's Tug of War competition.
<b>The Royal Navy Endeavour Cup</b>	Awarded to the Best turned-out Ladies Tug of War Team
<b>Worcestershire YFC Competition Day Winners – Ladies Tug of War</b>	Awarded to the team gaining the highest marks in the Ladies Tug of War competition.
<b>The David Goodwin Trophy</b>	Awarded for the most improved Club at the Show
<b>The Andrea Halford Trophy</b>	Awarded for the Club showing the best membership performance at the Show
<b>Mike Greaves Tankard ATV Challenge</b>	Awarded to the team gaining the highest marks in the ATV Handling competition.
<b>The Gerald Gilder Trophy for the Best Pair of Butchers Lambs</b>	Awarded for the Best Pair of Butchers Lambs

## Class 1 - Club Show Support Points

Entries: Required from each Club in the County.

Marks: Max **1000** towards the Show Championship Cup.

Procedure: Clubs to provide assistance / items as listed below for which points are added to clubs show day totals.

- Rules:
- 1 The Show General Rules apply to this competition – Please Read them – Front of Rule Schedule
  - 2 **Entries for this can be made as a representation for the club and therefore does not have to be a member, or within age range to gain points for the club.**
  - 3 **Clubs must ensure that the item / person is signed in when delivering / arriving for task.**
  - 4 **Three** Representatives from each club to assist with set-up duties.
  - 5 Each club to provide two table flower arrangements for officials catering.
  - 6 Each club to provide a dessert for the officials catering.
  - 7 Each club to provide a cake for the guest reception.
  - 8 **Two** Representatives from each club to assist with officials catering as per the rota.
  - 9 **Two** Representatives from each club to assist with public catering as per the rota.
  - 10 Valuable articles are the responsibility of the owner.

Marking: The following scale of marks will be observed

Setting up (Three people)	300
Officials Catering area table arrangements	100
Officials Catering area dessert	100
Guest reception - Cake	100
Officials Catering Assistance (Two people)	200
Public Catering Assistance (Two people)	200
<b>Total</b>	<b>1000</b>

## Class 2 - Show Advertisement Board

- Time: Booking in 08.45am. Ready by 09:00am.
- Entries: Competition is open to **one entry** per Club in the County.  
Exhibit to be staged by members **aged 26 and under** on 1st September 2018.  
**Competitors will be required to show their current membership cards when booking in.**
- Marks: Max 100 towards the Show Championship Cup.
- Procedure: Clubs to create and display a **Road – side Advertisement Board** to promote the County Show.
- Rules:
- 1 **The design must contain in full the following information:**
    - Worcestershire Federation of Young Farmers' Clubs County Show
    - Saturday 25 May 2019
    - Park Farm, WR5 3PD
    - For info call 01905 621616 or visit [www.worcsyfc.org.uk](http://www.worcsyfc.org.uk)
    - Open to the Public from 9-5.
    - Doo 8pm -1am
  - 2 **Size: (Maximum) 2440mm x 1220mm** aspect to club discretion (i.e. landscape or portrait).
  - 3 **Advertising boards must not be erected prior to Sunday 12<sup>th</sup> May 2019.** Boards erected prior to this date will contravene planning regulations.
  - 4 Boards must be erected on private property and this must be verified on your entry form. Boards **must not** be erected on the roadside, i.e. between the kerb and the hedge.
  - 5 Due safety consideration must be made to the positioning of the board so as not to cause any one any danger.
  - 6 **Precise location details must be provided to County Office by 20.00 hrs on Monday 6<sup>th</sup> May 2019.**
  - 7 **Boards will be judged without any notification during the period 15<sup>th</sup> May – 24<sup>th</sup> May 2019.**
  - 8 Boards will be judged on their location, position in a prominent place without obstruction of traffic etc., clarity of information, completeness of information as above, originality and workmanship.
  - 9 **Boards must be removed on Friday 24<sup>th</sup> May 2019** before the show and brought to the show site. Entries which are not in position on the show site by 09:00 on the day of the show **will be disqualified.**
  - 10 The Show General Rules apply to this competition – Please Read them – Front of Rule Schedule
  - 11 Each Club will be fully responsible for both staging and removing their own Exhibit and any debris after the show at the direction of the Show Management Team.
  - 12 Valuable articles are the responsibility of the exhibitors.
  - 13 The decision of the judge will be final.
  - 14 No Exhibit to be dismantled or removed from display before the end of the official prize giving or 17:00 hrs as directed by the Chief Steward on the day.
  - 15 No Club names or items that may distinguish which club exhibits belong to be displayed unless stated otherwise in the rules.

**Marking:** The following scale of marks will be observed

Clarity of display	35
Location/Position/Safety	15
Workmanship	25
Originality and ingenuity of design	25
<b>Total</b>	<b>100</b>



## Class 3 – Defford Advertising Banner

- Time: Forwarded to the office by email by **Friday 26<sup>th</sup> April 2019**.
- Entries: Competition is open to **one entry** per Club in the County.  
Exhibit to be staged by members **aged 26 and under** on 1st September 2018.  
**Competitors will be required to show their current membership cards when booking in.**
- Marks: Max 100 towards the Show Championship Cup.
- Procedure: Clubs to create an **electronic** (computerized) **Road – side Advertisement Banner** to promote the Defford Doo.
- Rules:
- 1 **The design must contain in full the following information:**
    - Defford Doo
    - Friday 19<sup>th</sup> July 2019
    - Hollybeds Farm, WR9 8DA
    - For info call 01905 621616 or visit [www.worcsyfc.org.uk](http://www.worcsyfc.org.uk)
    - Open to the Public
    - 9pm - 2am
  - 2 **Size: (Maximum) 5ft by 3ft Landscape.**
  - 3 The electronic file will need to be received by the county office as a PDF file no later than Friday 26<sup>th</sup> April.  
The winning banner will be displayed at the County Show and will then be used by county to advertise the Defford Doo.
  - 4 The decision of the judge will be final.
  - 5 No Exhibit to be dismantled or removed from display before the end of the official prize giving or 17:00 hrs as directed by the Chief Steward on the day.
  - 6 No Club names or items that may distinguish which club exhibits belong to be displayed unless stated otherwise in the rules.

**Marking:** The following scale of marks will be observed

Clarity of display	35
Location/Position/Safety	15
Workmanship	25
Originality and ingenuity of design	25
<b>Total</b>	<b>100</b>



## Class 4 - Main Exhibit

**Date/Time:** Friday 24<sup>th</sup> May 2019 **6.30pm – 8.30pm.**  
Saturday 25<sup>th</sup> May 2019 **7.00am – 7.45am.**  
**All exhibits to be staged ready for judging at 8.30am on Saturday 25th May 2019.**

**Entries:** Each Club may **make one entry** in this competition.  
**Competitors Will Be Required To Show Their Current Membership Cards.**

**Marks:** Maximum of 600 marks towards the Show Championship Cup.  
Maximum of 600 marks towards the Main Exhibit Cup.

### **Rules:**

1. Each exhibit to depict the theme **“Great British Holidays”** and to include one item of five different crafts (which have been made during the past 12 months by YFC members) Those items to be clearly marked 1 to 5 and up to 50 points will be awarded for each of the five items. Items used must not have been used in a previous Royal Three Counties Show.  
  
N.B. No edible items may be placed on the Exhibit until the Saturday morning of the Show. Items of cookery will only be tasted at the discretion of the judges. **All foodstuffs to be covered with cling film.**
2. Each Exhibit to have a **MAXIMUM WIDTH of 2440mm** at any given point and a **MAXIMUM DEPTH of 1830mm** and **MAXIMUM HEIGHT of 1830mm**. **Any exhibit exceeding the maximum measurements will be penalised.** Exhibits will be measured by the Chief Steward.
3. All Exhibits with electrical mechanisms must have main switches easily accessible and clearly marked in case at the front of the Exhibit. NOTE: Electrics on Exhibits will be PAT tested on the evening of Friday 24<sup>th</sup> May**2019** and if any electrical or mechanical device is deemed to be unsafe by the Committee, it will be disconnected.
4. No names of clubs to be marked on any exhibits.
5. The Exhibit to be staged by members **26 years of age or under** on 1<sup>st</sup> September 2018. No assistance will be allowed under penalty of disqualification.
6. There will be no admittance to the Show Ground before 6.30pm on Friday 24<sup>th</sup> May2019.
7. The following scale of marking will be observed:

5 items of different crafts (50pts each)	250
Attractiveness of Exhibit	125
Originality and Ingenuity	125
Relevance of craft to theme	100
<b>Total Per Exhibit</b>	<b>600</b>
8. No exhibits in any competition may be removed before the prize giving on 25<sup>th</sup> May Saturday 25<sup>th</sup> May2019, unless otherwise directed by the Chief Steward. Failure to comply will result in all marks awarded for the competition concerned being removed and the competitors disqualified.

## Class 5 - Junior Exhibit

### Date/Time:

Friday 24<sup>th</sup> May 2019 **6.30pm – 8.30pm.**

Saturday 25<sup>th</sup> May 2019 **7.00am – 7.45am.**

**All exhibits to be staged ready for judging at 7.45am on Saturday 25<sup>th</sup> May 2019.**

### Entries:

Each Club may **make one entry** in this competition.

**Competitors Will Be Required To Show Their Current Membership Cards.**

### Marks:

Maximum of 300 marks towards the SHOW CHAMPIONSHIP CUP

Maximum of 300 marks towards the Junior Events Cup

### Award:

The will be awarded to the winning Club.

### Rules:

- The Exhibit to be staged and set up by members 16 years of age and under on 1<sup>st</sup> September 2018. People over 16 will NOT be allowed to help with the setting up of the Exhibit on Thursday night but are able to help on Friday morning with putting items to be judged on the exhibit IF NO UNDER 16's ARE PRESENT.** Failure to comply with this rule will result in disqualification.
- Each Exhibit to depict the theme **“HOLIDAYS”** The interpretation of the theme to be of the Club's own choice. A list of all items made by the competitors is to be attached to the Exhibit for the purpose of assisting judging. Five different crafts are to be clearly marked 1 to 5 so that the judges can award points for these individually. It is expected that further craft items will be included in the exhibit and judged as per the mark scheme. All crafts must have been made during the past 12 months by members, **16 years of age or under.** Craft items must not have been used at a previous Royal Three Counties Show.  
N.B. No edible items may be placed on the Exhibit until the Friday morning of the Show. Items of cookery will only be tasted at the discretion of the judges. **All foodstuffs to be covered with cling film.**
- The Exhibit is to be staged on a table. Maximum **height of the exhibit is 1020mm from tabletop.** A **1830mm x 685mm** table will be provided, **EXHIBITS SHOULD NOT EXCEED THE TABLE MEASUREMENTS** (except where a cloth has been used to cover the table). The front of the table may be covered and may be used as part of the Exhibit. **Exhibits will be measured by the Chief Steward.**
- Battery power is allowed for powering items within the exhibit. The use of car batteries **is NOT** allowed however.
- No names of clubs to be marked on any exhibits.
- There will be no admittance to the Show Ground before 6.300am on Saturday 25<sup>th</sup> 2019.
- The following scale of marking will be observed:

Quality & depth of research	50
5 items of different crafts (20pts each)	100
Additional craft items	30
Overall effect	60
Relevance of crafts to theme	30
Quality of display & staging	30
<b>Total Per Exhibit</b>	<b>300</b>
- No exhibits in any competition may be removed before the presentation of the on Saturday 25<sup>th</sup> May Saturday 25<sup>th</sup> May, unless otherwise directed by the Chief Steward. Failure to comply will result in all marks awarded for the competition concerned being removed and the competitors disqualified.



## **Class 6 - Cube Exhibit**

Date/Time: **Fiday 24th May 2019** 6.30pm – 8.30pm.  
**Saturday 25th May 2019** 7.00am – 7.45am.  
All exhibits to be staged ready for judging at 8.30am on Saturday 25th May 2019.

Entries: **Each Club can make one entry in this competition.**  
Competitors Will Be Required To Show Their Current Membership Cards.

Marks: **Maximum of 400 marks towards the SHOW CHAMPIONSHIP CUP**

### **Rules:**

1. **Each Exhibit to depict the theme “CHILDREN’S TELEVISION” The interpretation of the theme to be of the Club's own choice.**

2. The cube is to contain 5 crafts, 1 craft from each of the headings listed below:  
Craft 1 - Floral Art (Any item using cut flowers and accessories in a suitable container)  
Craft 2 – Cookery/Baking (This craft will be tasted so must be covered with cling film).  
Craft 3 – Textile Handicraft (must include British Wool) (Knitwear, Tailored, Crochet for example)  
Craft 4 – Natural Handicraft (Any item using wood, metal, clay, glass, stone or shell for example)  
Craft 5 – Art (An item that could include photography, a graphic or a picture in any medium)

The five (5) crafts need to be clearly marked 1-5 together with the heading the craft comes under. For example 1- Floral Art, 2 – Cookery, 3- Sewn Handicraft, 4- Natural Handicraft, 5- Art Handicraft.

**All crafts must have been made during the past 12 months by members. Craft items must not have been used at a previous Royal Three Counties Show.**

**N.B. No edible items may be placed on the Exhibit until the Friday morning of the Show. Items of cookery will only be tasted at the discretion of the judges.** All foodstuffs to be covered with cling film.

3. Each whole Exhibit to have a **MAXIMUM WIDTH of 1 meter** at any given point and a **MAXIMUM DEPTH of 1 meter** and **MAXIMUM HEIGHT of 1 meter**. Any exhibit exceeding the maximum measurements will be disqualified. The measurement will be from the outside edges of the external walls of the exhibit. (I.e. Make your exhibit slightly smaller than the maximum dimensions). Any accessories or drapes used on the outside of the external walls of the cube will be included in the overall measurement of the exhibit. The external walls will be taken into account for the attractiveness of the exhibit marks and so should be covered to compliment the overall exhibit. The exhibit must have 3 walls. Exhibits will be measured by the Chief Steward.

4. No names of clubs to be marked on any exhibits.

5. The following scale of marking will be observed:

Craft 1 – Floral Art	50
Craft 2 – Cookery	50
Craft 3 – Textile	50
Craft 4 – Natural	50
Craft 5 – Art	50
Attractiveness of Exhibit (including external walls)	50
Originality & ingenuity	50
Relevant to theme	50
Total	400

6. **No exhibits in any competition may be removed before the prize giving on Saturday 25th May 2019, unless otherwise directed by the Chief Steward. Failure to comply will result in all marks awarded for the competition concerned being removed and the competitors disqualified.**

## Class 7 - YFC Showcase

**Date/Time:** Friday 24<sup>th</sup> May 2019 6.30pm – 8.30pm  
Saturday 25<sup>th</sup> May 2019 7.00 - 7.45am

**All exhibits to be staged ready for judging at 9:00am on Saturday 25<sup>th</sup> May 2019.**

**Entries:** Each Club may **make ONE entry** in this competition.  
**Competitors Will Be Required To Show Their Current Membership Cards.**

**Marks:** Maximum 100 per entry.  
Maximum of 100 marks towards the SHOW CHAMPIONSHIP CUP.

### **Rules:**

1. The Exhibit to be staged and set up by current members **26 years of age or under** on 1<sup>st</sup> September 2018. No assistance will be allowed under penalty of disqualification.
2. Each Exhibit to showcase **“Our Young Farmers’ County”**. The interpretation of the theme to be of the club’s own choice, however the following guidelines of information to be included and research are advised to be followed –
  - Include club locations, contact details and meeting days
  - Include take home leaflets with club and county details on
  - To Include cake decorating, needlework, flower arranging, Metalwork and Woodwork
  - Reference to NFYFC opportunities
  - Representation of your county outside of YFC
3. A list of all items is to be attached to the exhibit for the purpose of assisting judging.
4. The exhibit to be staged on a table measuring **1830mm x 685mm will be provided** – EXHIBITS SHOULD NOT EXCEED THE TABLE MEASUREMENTS (except where a cloth has been used to cover the table). The front of the table may be covered and may be used as part of the exhibit. Exhibits will be measured by the Exhibit Chief Steward. While there is no maximum height, any exhibits deemed unstable by the Chief Steward will be removed.
5. Battery power is allowed for powering items within the exhibit. The use of car batteries is NOT allowed.
6. The following scale of marking will be observed:

Overall effect	30
Quality of display and staging	20
Quality of information & depth of research	50
<b>Total Per Exhibit</b>	<b>100</b>
7. No exhibits in any competition may be removed before the prize giving on Saturday 25<sup>th</sup> May 2019, unless otherwise directed by the Chief Steward. Failure to comply will result in all marks awarded for the competition concerned being removed and the competitors disqualified.

## Class 8 - Photography – Senior

**Date/Time:** Saturday 25<sup>th</sup> May 2019 Booking in at 9.00am

**All exhibits to be staged ready for judging at 9.30am on Saturday 25<sup>th</sup> May 2019.**

**Entries:** Each Club may **make one entries** in this competition. Competitors must be **26 years of age or under** on 1<sup>st</sup> September 2018. **Competitors Will Be Required To Show Their Current Membership Cards.**

**Marks:** Maximum of 100 marks towards the SHOW CHAMPIONSHIP CUP.  
Maximum of 100 marks towards the JUBLIEE CUP.

**Rules:**

1. The competitor will be required to produce **3 photographs, 6" x 4"**, mounted on an **A3 Mount board** to the theme **"Life by the Beach"**.

**Any exhibit exceeding the maximum measurements will be penalised. Photos must be presented on mount board only and NOT in clip presentation frames.**

2. A length of string and clips will be provided on the day to hang the A3 Mount Boards from to display.

3. Photographs can be captured using film or digital photography.

4. If digital photography is used as the capture method the photographs **MUST NOT** be digitally enhanced using photographic software on a computer. The preferred printing method would be to print the photos from the memory card using a commercial photo machine.

5. If a photo machine is used the appropriate size can be selected and the image can be turned into black & white, sepia or colour but no other alterations can be done for example cropping images, brightness/contrast, colour restoration/balance or any method which would digitally alter the photo quality.

6. Photos should be self explanatory but a short sentence or title under each photo would be allowed (10 words maximum) or a three sentence script (30 words maximum) anywhere on the A3 board. Text should be separate and NOT within a photograph or this will be perceived as being digitally enhanced.

7. The photographs must have been taken by members of a Young Farmers' Club 26 years of age or under on 1<sup>st</sup> September 2018 and may be trade processed. **Competitor's name, membership number, Club and County name must be attached to the reverse of the display board.** No names of clubs or counties to be marked on the front of the exhibits.

8. The following scale of marking will be observed:

Each photograph (20pts each)	60
Display	20
Relevance to theme	20
<b>Total per competitor</b>	<b>100</b>

9. No exhibits in any competition may be removed before the presentation of on Saturday 25<sup>th</sup> May 2019, unless otherwise directed by the Chief Steward. Failure to comply will result in all marks awarded for the competition concerned being removed and the competitors disqualified.

## Class 9 - Photography – Intermediate

**Date/Time:** Saturday 25th May 2019 Booking in at 9.00am.

**All exhibits to be staged ready for judging at 9.30am on Saturday 25th May 2019.**

**Entries:** Each Club can make one entry in this competition. Competitors must be **under 21 years of age or under** on 1<sup>st</sup> September 2018. **Competitors Will Be Required To Show Their Current Membership Cards.**

**Marks:** Maximum of 100 marks towards the SHOW CHAMPIONSHIP CUP  
Maximum of 100 marks towards the JUBLIEE CUP

**Rules:**

1. The competitor will be required to produce **3 photographs, 6" x 4"**, mounted on an **A3 Mount board** to the theme **“Topping up the Tan”**.

**Any exhibit exceeding the maximum measurements will be penalised. Photos must be presented on mount board only and NOT in clip presentation frames.**

2. A length of string and clips will be provided on the day to hang the A3 Mount Boards from to display.

3. Photographs can be captured using film or digital photography.

4. If digital photography is used as the capture method the photographs **MUST NOT** be digitally enhanced using photographic software on a computer. The preferred printing method would be to print the photos from the memory card using a commercial photo machine.

5. If a photo machine is used the appropriate size can be selected and the image can be turned into black & white, sepia or colour but no other alterations can be done for example cropping images, brightness/contrast, colour restoration/balance or any method which would digitally alter the photo quality.

6. Photos should be self explanatory but a short sentence or title under each photo would be allowed (10 words maximum) or a three sentence script (30 words maximum) anywhere on the A3 board. Text should be separate and **NOT** within a photograph or this will be perceived as being digitally enhanced.

7. The photographs must have been taken by members of a Young Farmers' Club 21 years of age or under on 1<sup>st</sup> September 2018 and may be trade processed. **Competitor's name, membership number, Club and County name must be attached to the reverse of the display board.** No names of clubs or counties to be marked on the front of the exhibits.

8. The following scale of marking will be observed:

Each photograph (20pts each)	60
Display	20
Relevance to theme	20
<b>Total per competitor</b>	<b>100</b>

9. No exhibits in any competition may be removed before the prize giving on Saturday 25th May 2019, unless otherwise directed by the Chief Steward. Failure to comply will result in all marks awarded for the competition concerned being removed and the competitors disqualified.

## Class 10 - Photography – Junior

**Date/Time:** Saturday 25th May 2019 Booking in at 9.00am.

**All exhibits to be staged ready for judging at 9.30am on Saturday 25th May 2019.**

**Entries:** Each Club can make one entry in this competition. Competitors must be **under 16 years of age or under** on 1<sup>st</sup> September 2018. **Competitors Will Be Required To Show Their Current Membership Cards.**

**Marks:** Maximum of 100 marks towards the JUNIOR EVENTS CUP  
Maximum of 100 marks towards the SHOW CHAMPIONSHIP CUP

### **Rules:**

1. The competitor will be required to produce **3 photographs, 6" x 4"**, mounted on an **A3 Mount** board to the theme **"Guess Which Holiday"**.

**Any exhibit exceeding the maximum measurements will be penalised. Photos must be presented on mount board only and NOT in clip presentation frames.**

2. A length of string and clips will be provided on the day to hang the A3 Mount Boards from to display.
3. Photographs can be captured using film or digital photography.
4. If digital photography is used as the capture method the photographs MUST NOT be digitally enhanced using photographic software on a computer. The preferred printing method would be to print the photos from the memory card using a commercial photo machine.
5. If a photo machine is used the appropriate size can be selected and the image can be turned into black & white, sepia or colour but no other alterations can be done for example cropping images, brightness/contrast, colour restoration/balance or any method which would digitally alter the photo quality.
6. Photos should be self explanatory but a short sentence or title under each photo would be allowed (10 words maximum) or a three sentence script (30 words maximum) anywhere on the A3 board. Text should be separate and NOT within a photograph or this will be perceived as being digitally enhanced.
7. The photographs must have been taken by members of a Young Farmers' Club 16 years of age or under on 1<sup>st</sup> September 2017 and may be trade processed. **Competitor's name, membership number, Club and County name must be attached to the reverse of the display board.** No names of clubs or counties to be marked on the front of the exhibits.
8. The following scale of marking will be observed:

Each photograph (20pts each)	60
Display	20
Relevance to theme	20
<b>Total per competitor</b>	<b>100</b>

9. No exhibits in any competition may be removed before the prize giving on Saturday 25th May 2019, unless otherwise directed by the Chief Steward. Failure to comply will result in all marks awarded for the competition concerned being removed and the competitors disqualified.

## Class 11 - Craft – Senior

**Date/Time:** Saturday 25th May 2019 Booking in at 8.45  
**All exhibits to be staged ready for judging at 9.00am on Saturday 25th May 2019.**

**Entries:** Each Club can make one entry in this competition. Competitors must be **26 years of age or under** on 1<sup>st</sup> September 2018. **Competitors Will Be Required To Show Their Current Membership Cards.**

**Marks:** Maximum of 100 marks towards the SHOW CHAMPIONSHIP CUP  
Maximum of 100 marks towards the JE.  
Maximum of 100 marks towards the VENABLES SHIELD.

### **Rules:**

1. The Competitor is required to produce a **“Holiday Resort Diorama”**.
2. A Diorama to be displayed to depict a holiday resort. A table will be available to display the craft. The choice of materials is the competitor's own. Battery power is allowed for powering items within the exhibit, however the use of 12volt batteries is not permitted on any part of the exhibit,
3. The exhibit should be a MAXIMUM size of **900mm x 600mm**, no maximum height
4. The exhibit should be suitable for a family audience
5. No names of clubs or counties to be marked on any exhibits.
7. The following scale of marking will be observed:

Use of materials	20
Quality of workmanship	20
Originality	30
Overall finish	30
<b>Total</b>	<b>100</b>
8. No exhibits in any competition may be removed before the prize giving on Saturday 25th May 2019, unless otherwise directed by the Chief Steward. Failure to comply will result in all marks awarded for the competition concerned being removed and the competitors disqualified.

## Class 12 - Craft – Intermediate

**Date/Time:** Saturday 25th May 2019 Booking in at 8.45am.

**Exhibits to be staged for Judging at 9.00am on Saturday 25th May 2019.**

**Entries:** Each Club can make one entry in this competition. Competitors must be **21 years of age or under** on 1<sup>st</sup> September 2018. **Competitors Will Be Required To Show Their Current Membership Cards.**

**Marks:**

Maximum of 100 marks towards SHOW CHAMPIONSHIP CUP.

Maximum of 100 marks towards VENABLES SHIELD.

Maximum of 100 marks towards JUBLIEE CUP.

**Rules:**

1. Competitors are required to make a **“Deck Chair”**.
2. Competitors are required to build the craft beforehand.
3. Photos should be provided of different stages of making the Deck Chair.
4. The display area must not exceed **600mm Wide x 1200mm Deep, Rear height 1000mm. Front Height 440mm**
5. No names of clubs or counties to be marked on any exhibits.
6. The following scale of marking will be observed:

Use of materials	20
Quality of workmanship	20
Originality	30
Overall finish	30
<b>Total</b>	<b>100</b>

7. No exhibits in any competition may be removed before the prize giving on Saturday 25th May 2019, unless otherwise directed by the Chief Steward. Failure to comply will result in all marks awarded for the competition concerned being removed and the competitors disqualified.

## Class 13 - Craft – Junior

**Date/Time:** Saturday 25th May 2019 Booking in at 8.45am.  
**Exhibits to be staged for Judging at 9.00am on Saturday 25th May 2019.**

**Entries:** Each Club can make one entry in this competition. Competitors must be **16 years of age or under** on 1<sup>st</sup> September 2018. **Competitors Will Be Required To Show Their Current Membership Cards.**

**Marks:** Maximum of 100 marks towards the SHOW CHAMPIONSHIP CUP.  
Maximum of 100 marks towards the VENABLES SHIELD.  
Maximum of 100 marks towards the JUNIOR EVENTS CUP

**Rules:**

1. Competitors are required to make a piece of **“Festival Head Gear”**.
2. To be made prior to the competition day.
3. Any materials can be used.
4. Only a table will be available to display the craft, stand should be provided by the competitor.
5. The exhibit should be a **MAXIMUM** size of **600mm x 600mm**, no maximum height.
6. All exhibits must be the unaided work of the competitors.
7. The following scale of marking will be observed:

Use of materials	20
Quality of workmanship	20
Originality	30
Overall finish	30
<b>Total</b>	<b>100</b>

8. No exhibits in any competition may be removed before the prize giving on Saturday 25th May 2019, unless otherwise directed by the Chief Steward. Failure to comply will result in all marks awarded for the competition concerned being removed and the competitors disqualified.



## Class 14 - Metalwork

**Date/Time:** Saturday 25th May 2019 Booking in at 8.45am.

**All exhibits to be staged ready for judging at 9.00am on Saturday 25th May 2019.**

**Entries:** Each Club can make one entry in this competition. Competitors must be **26 years of age or under** on 1<sup>st</sup> September 2018. **Competitors Will Be Required To Show Their Current Membership Cards.**

**Marks:** Maximum of 100 marks towards the SHOW CHAMPIONSHIP CUP  
Maximum of 100 marks towards the VENABLES SHIELD  
Maximum of 100 marks towards The Will Davise Trophy

**Rules:**

1. Competitors will be required to produce a **“Free Standing Sundial”**.
2. Size not to exceed **600mm (L) X 600mm (W) by 1000mm (H)** Maximum Weight limit of **20 kilograms** for completed metalwork; to be a minimum height of 300mm x 400mm x 500mm. Finished with an exterior treatment for suitability to display in the open air. There will be no points for the use of laser cutters.
3. The construction is to have a flat plate and an gnomon which cast a shadow onto the dial.
4. The sundial must stand freely
5. Competitor's membership number must be attached to the bottom of the exhibit. No names of clubs or counties to be marked on the front/sides of the exhibits.
6. The following scale of marking will be observed:

Construction and craftsmanship	50
Overall finished effect	25
Effectiveness and impact in the Sun	25
<b>Total</b>	<b>100</b>

7. Please note that the exhibits may be displayed in front of the Show Ground for the duration of the Show. Members of the committee will move exhibits into the marquee overnight.
8. No exhibits in any competition may be removed before the prize giving on Saturday 25th May 2019, unless otherwise directed by the Chief Steward. Failure to comply will result in all marks awarded for the competition concerned being removed and the competitors disqualified.

## Class 15 - YFC Bake Off - Senior

**Date/Time:** Saturday 25th May 2019 Booking in at 9.00am.

**All exhibits to be staged ready for judging at 9.30am on Saturday 25th May 2019.**

**Entries:** Each Club can make one entry in this competition. Competitors must be **26 years of age or under** on 1<sup>st</sup> September 2018. **Competitors Will Be Required To Show Their Current Membership Cards.**

**Marks:** Maximum of 100 marks towards the SHOW CHAMPIONSHIP CUP.  
Maximum of 100 marks towards the VENABLES SHIELD.  
Maximum of 100 marks towards the JUBLIEE CUP.

### **Rules:**

1. Each competitor is required to make a **“Picnic”**. The picnic should be displayed in a basket, and is to be made in advance and staged on the day of competition.
2. The display area must not exceed **500mm x 500mm**, unlimited height.
3. The Basket to be filled with homemade items suitable for a picnic.
4. The Basket to include a drink of competitors choice.
5. A list of items within the basket must be displayed.
6. The following scale of marking will be observed:

Variety of Items	30
Taste	25
Display	30
Overall effect	15
<b>Total</b>	<b>100</b>
7. No exhibits in any competition may be removed before the prize giving on Saturday 25th May 2019, unless otherwise directed by the Chief Steward. Failure to comply will result in all marks awarded for the competition concerned being removed and the competitors disqualified.

## Class 16 - YFC Bake Off - Intermediate

**Date/Time:** Saturday 25th May 2019 Booking in at 9.00am.

**All exhibits to be staged ready for judging at 9.30am on Saturday 25th May 2019.**

**Entries:** Each Club can make one entry in this competition. Competitors must be **21 years of age or under** on 1<sup>st</sup> September 2018. **Competitors Will Be Required To Show Their Current Membership Cards.**

**Marks:** Maximum of 100 marks towards the SHOW CHAMPIONSHIP CUP.  
Maximum of 100 marks towards the VENABLES SHIELD.  
Maximum of 100 marks towards the JUBLIEE CUP.

**Rules:**

1. Each competitor is required to make a cake to the theme of **“Caravan Carrot Cake”**. The carrot cake is to be made in advance and staged on the day of competition.
2. The display area must not exceed **500mm x 500mm**, there is no height limit.
3. The decoration and presentation of the carrot cake is the competitor's choice. Accessories to be kept to a minimum.
4. **PLEASE NOTE** - In addition to the 'Caravan Carrot Cake, competitors are required to display details of recipes used, including ingredients and their method. A description of how the cake was made must also be displayed along with 4 photographs showing the different stages.
5. The following scale of marking will be observed:

Finished	30
Taste	25
Display	20
Overall effect	10
Descriptive card & photographs	15
<b>Total</b>	<b>100</b>

6. No exhibits in any competition may be removed before the prize giving on Saturday 25th May 2019, unless otherwise directed by the Chief Steward. Failure to comply will result in all marks awarded for the competition concerned being removed and the competitors disqualified.

## Class 17 - YFC Bake Off - Junior

**Date/Time:** Saturday 25th May 2019 Booking in at 9.00am.

**All exhibits to be staged ready for judging at 9.30am on Saturday 25th May 2019.**

**Entries:** Each Club can make one entry in this competition. Competitors must be **16 years of age or under** on 1<sup>st</sup> September 2018. **Competitors Will Be Required To Show Their Current Membership Cards.**

**Marks:** Maximum of 100 marks towards the SHOW CHAMPIONSHIP CUP.  
Maximum of 100 marks towards the VENABLES SHIELD.  
Maximum of 100 marks towards the JUNIOR EVENTS CUP.

### **Rules:**

1. Each competitor is required to make **"4 Sea Shell Biscuits"**. The biscuits are to be made in advance and staged on the day of competition.
2. The display area must not exceed **500mm x 500mm**, there is no height limit.
3. The decoration and presentation of the Biscuits to be the competitor's choice. Accessories to be kept to a minimum.
4. **PLEASE NOTE** - In addition to the Biscuits, competitors are required to display details of recipes used, including ingredients and their method. A description of how the biscuits were made and decorated must also be displayed along with 4 photographs of the different stages
5. The following scale of marking will be observed:

Finished Biscuits	30
Taste	25
Display	20
Overall effect	10
Descriptive card and photographs	15
<b>Total</b>	<b>100</b>

6. No exhibits in any competition may be removed before the prize giving on Saturday 25th May 2019, unless otherwise directed by the Chief Steward. Failure to comply will result in all marks awarded for the competition concerned being removed and the competitors disqualified.

## Class 18 - Needlework

**Date/Time:** Saturday 25th May 2019 Booking in at 8.45am.

**All exhibits to be staged ready for judging at 9:00am on Saturday 25th May 2019.**

**Entries:** Each Club can make one entry in this competition. Competitors must be **26 years of age or under** on 1<sup>st</sup> September 2018. **Competitors Will Be Required To Show Their Current Membership Cards.**

**Marks:** Maximum of 200 marks towards the SHOW CHAMPIONSHIP CUP.  
Maximum of 200 marks towards the VENABLES SHIELD.

### **Rules:**

1. Competitors are required to make a **"Picnic Blanket"**. The blanket can be hand or machine sewn.
2. **PLEASE NOTE** - In addition to the blanket, competitors are required to display details of how the blanket was made along with 4 photographs mounted on a board of the different stages of production. The choice of material used is the competitor's own.
3. The blanket must have been made within the 5 months prior to the Show.
4. No names of clubs or counties to be marked on any exhibits.
5. The following scale of marking will be observed:

Choice of fabric	20
Construction and sewing skills	40
Overall appearance	25
Board design and display	15
<b>Total per competitor</b>	<b>100</b>

6. No exhibits in any competition may be removed before the prize giving on Saturday 25th May 2019, unless otherwise directed by the Chief Steward. Failure to comply will result in all marks awarded for the competition concerned being removed and the competitors disqualified.

## Class 19 & 20 - Sheep Shearing – Senior & Intermediate

**Date/Time:** Saturday 25th May 2019

All competitors to report to the shearing shed at **11.30am** ready to start at **12.00pm**.

### **Entries:**

Each Club in the county may make as many entries as they like, provided each competitor has attend the Blue Seal in sheep shearing to ensure their competence. This rule is to be strictly applied – No late entries will be accepted.

### **Marks:**

Maximum 100 marks per competitor. To be calculated by deducting penalty points from 100.

Maximum of 100 marks towards the SHOW CHAMPIONSHIP CUP.

Maximum of 100 marks towards the Team Shearing Cup

(Highest placed Senior & Intermediate competitor from each club) See note below.

### **Note:**

**Blue Seal certificate of competence and this will be required to be shown when booking in for this competition.**

### **Rules:**

1. **Senior Competitors** must both be **26 years of age or under** on 1<sup>st</sup> September 2018. **Competitors Will Be Required To Show Their Current Membership Cards.**
2. **Intermediate Competitors** must both be **21 years of age or under** on 1<sup>st</sup> September 2018. **Competitors Will Be Required To Show Their Current Membership Cards.**
3. Maximum time allowed: **FIFTEEN MINUTES – SENIOR COMPETITION**  
**TWENTY MINUTES – INTERMEDIATE COMPETITION**
4. Each competitor will be required to shear two sheep in any recognized style within the time allowed.
  - a) **Senior** - Competitors will be allowed 15 minutes each to catch and shear. Competitors taking more than the time allowed will be penalized at a rate of 1 mark for every 30 seconds or part thereof taken over time. Competitors will be required to wrap their wool after the allocated time.
  - b) **Intermediate** - Competitors will be allowed 20 minutes each to catch and shear. Competitors taking more than the time allowed will be penalized at a rate of 1 mark for every 30 seconds or part thereof taken over time. Competitors will be required to wrap their wool after the allocated time.
5. The Chief Shearing Steward may stop any competitor who shows signs of difficulty or incompetence.
6. The draw for individual pen numbers will be held prior to the competition.
7. A draw for heats and stands will be made before the start of each competition.
8. Competitors may ask for any sheep considered to be sub-standard to be re Cupted before the heats commence. The Chief Shearing Steward's decision shall be final.
9. Competitors must wear suitable clothing and footwear. The Chief Shearing Steward will administer this ruling at all times.
10. Competitors will be allowed to take two loaded handpieces on to the boards and no time will be allowed for stoppages caused by either handpiece or the competitor's own sheep escaping. If any stoppages occur through faults in the machine or down-tube, or through other competitors' sheep escaping, a time allowance will be made or a re-run given, at the Chief Shearing Steward's discretion.
11. No competitor will be allowed in his or her pen except in the presence of a Judge and with the consent of the Chief Shearing Steward.

12. Each competitor may be allowed one person in his or her pen to act as second. The second may only assist the competitor by holding the sheep with all four feet on the ground but must not switch the machine on or off.
13. Without assistance each shearer must:
  - a) Start and stop (after each sheep) his machine.
  - b) Shear his sheep, and
  - c) Put each shorn sheep away properly.
14. Competitors will wait on the boards with one hand on the closed door for the word "GO". Each competitor will be separately timed from the word "GO" until he has switched off his machine after shearing his last sheep.
15. Each competitor's board penalties will be calculated by dividing the total number of Judges' strokes by sheep shorn.
16. Each competitor's pen penalties will be calculated by dividing the average Judges' strokes by sheep shorn.
17. The Chief Shearing Steward, in consultation with any Judge, has the right to disqualify any competitor whose work or conduct on the boards is detrimental to the good reputation of competition shearing.
18. The Chief Shearing Steward's ruling on any matter not covered by these rules shall be final.
19. Competitors are required to attend at the Shearing Shed in the Showground thirty minutes before the time stated in the programme for the commencement of their competition. Latecomers will be disqualified.
20. Any spare sheep will be shorn by competitors after the competition.

## Class 21 - Floral Art – Senior

**Date/Time:** Saturday 25th May 2019  
Booking in at **10.45am** ready to start at **11.00am**.

**Entries:** Each Club can make one entry in this competition. Competitors must be **26 years of age or under** on 1<sup>st</sup> September 2018. **Competitors Will Be Required To Show Their Current Membership Cards.**

**Marks:** Maximum of 100 marks towards the SHOW CHAMPIONSHIP CUP.  
Maximum of 100 marks towards the VENABLES SHIELD  
Maximum of 100 marks towards the JUBLIEE CUP

### **Rules:**

1. Maximum time allowed **ONE HOUR** and a further five minutes to check arrangements have not been disturbed during clearing up. Competitors may unpack their equipment and plant material before the hour starts, they may also be able to set up their display area.
2. Each competitor will be required to produce an exhibit to the title: **“Great Inventions That Changed The World”**.
3. Exhibit is to be viewed from the front. Competitors own backboard and base boards are allowed, and must be provided by the competitor if required and must adhere to the size limitations. **The reverse of these backboards MUST compliment the theme and be neat and tidy.**
4. The arrangement is to be composed of natural plant material, with or without accessories.
5. **Measurements**  
The arrangement must be contained within a space measuring **600mm wide X 600mm deep X optional height**; there is no limit to the height of the display. Table covering will be in white. Exhibits to be viewed from the front.

Diagram showing width, depth and height, remembering to include thickness of wood or overhanging drapes etc.

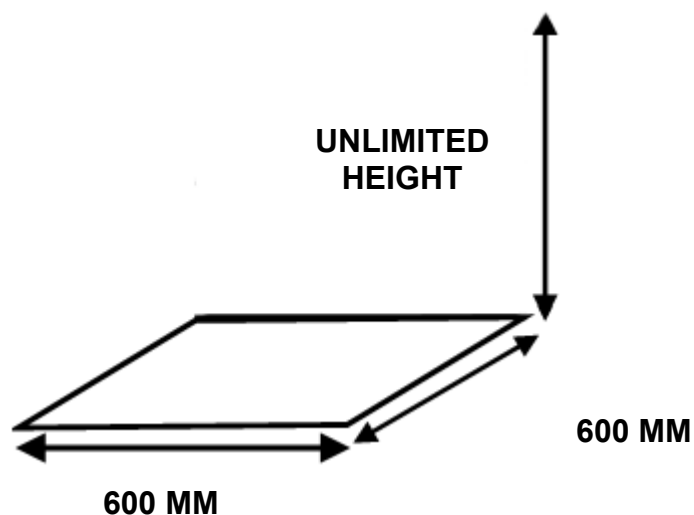

*Just remember – it is better to aim to be 1cm or 1 inch smaller than the size allowed as the size stated is the MAXIMUM size.*

6. All the work of arranging materials must be carried out at the competition.
7. **All exhibits must be the unaided work of the competitors.** During the period of the competition, competitors must not communicate directly or indirectly with any person other than Judges and



Stewards under penalty of instant disqualification. No other person, other than the competitors, will be allowed in the competing area.

8. Competitors must wear clean white coats during the competition.

9. The following scale of marking will be observed:

Idea	20
Colour	20
Composition	20
Technical	40
<b>Total</b>	<b>100</b>

10. No exhibits in any competition may be removed before the prize giving on Saturday 25th May 2018, unless otherwise directed by the Chief Steward. Failure to comply will result in all marks awarded for the competition concerned being removed and the competitors disqualified.

**PLEASE ALSO NOTE THE FOLLOWING:**

A. **ALL EXHIBITS WILL BE JUDGED STRICTLY IN ACCORDANCE WITH THE NAFAS COMPETITIONS MANUAL 2009.** A "Competitions Manual" is available from NAFAS Enterprises Ltd, Osborne House, 12 Devonshire Square, London EC2M 4TE, price £5.00 plus postage. [www.nafas.org.uk](http://www.nafas.org.uk) to visit the NAFAS on-line shop.

B. NAFAS Definitions (**The National Association of Flower Arranging Societies of Great Britain**) From the **NSAFAS Competitors Manual (Second Edition 2009)**.

C. An **EXHIBIT**:

- Is composed of natural plant material, with or without accessories, contained within a space as specified in a show schedule.
- Backgrounds, bases, containers, drapes, exhibit titles and mechanics may always be included in an exhibit, unless otherwise stated.
- More than one placement may always be included, unless otherwise stated.
- In all exhibits (except still life) natural plant material **must** predominate.

D. **NATURAL PLANT MATERIAL**

- Natural plant material is any vegetable matter
- It includes fresh, dried, garden, wild, or made-up plant material flowers, foliage, fruit, fungi, vegetables, seaweed meat (cooked or raw).
- NOTE: It is acceptable to enhance plant material by the application of oil, milk, wax or other similar products.

E. An **ACCESSORY**

- Anything other than natural plant material in an exhibit, such as, feathers, shapes (spheres, cones), shells, stones, wax candles
- Natural plant material which has been tooled or crafted to resemble non-plant forms, e.g. birds nest, corn dolly, wooden figurine.
- Accessories may be decorated in any way but greater credit should be given for the use of natural plant material where appropriate.
- The following **are not** accessories and may also be used unless prohibited by the show schedule: backgrounds, bases, containers holding plant material, drapes, exhibit titles and mechanics. These may be decorated in any way but greater credit should be given for use of natural plant material where appropriate.

F. Please also note:

**REASONS FOR DISQUALIFICATION**

- Failure to comply with any specific requirements of a class as stated in a show schedule, i.e. the measurements or the components. (Just remember – it is better to aim to be 1xm or 1 inch smaller than the size allowed as the size stated is the MAXIMUM size).
- Inclusion of artificial plant material (unless specifically allowed by a show schedule)
- Inclusion of fresh plant material that does not have roots or the cut ends of stems in water or water-retaining material. Exceptions: Air Plants, Cacti, Fruits, Grass Turf, Lichen, Moss, Succulents, Vegetables and long lasting plant material which will remain turgid for the duration of a show. (Definition of turgid – the state of firmness of plant tissue resulting from adequate moisture, causing the plant cells to be fully expanded).

G. **NOT ACCORDING TO SCHEDULE DISQUALIFICATION:**

- 'Not according to schedule' is the term used when an exhibit does not comply with the requirements of the schedule – see NAFAS reasons for disqualification above. The judge will write 'Not according to schedule' and the reason.



## Class 22 - Floral Art – Intermediate

**Date/Time:** Saturday 25th May 2019.  
Booking in at **9.15am** to start at **9.30am**.

**Entries:** Each Club can make one entry in this competition. Competitors must be **21 years of age or under** on 1<sup>st</sup> September 2018. **Competitors Will Be Required To Show Their Current Membership Cards.**

**Marks:** Maximum of 100 marks towards the SHOW CHAMPIONSHIP CUP.  
Maximum of 100 marks towards the VENABLES SHIELD  
Maximum of 100 marks towards the JUBLIEE CUP

**Rules:**

1. Maximum time allowed **ONE HOUR** and a further five minutes to check arrangements have not been disturbed during clearing up. Competitors may unpack their equipment and plant material before the hour starts, they may also be able to set up their display area.
2. Each competitor will be required to produce an exhibit to the title – **“Great Craftmanship”**. (An exhibit to depict a particular craft).
3. Exhibit is to be viewed from the front. Competitors own backboard and base boards are allowed, and must be provided by the competitor if required and must adhere to the size limitations. **The reverse of these backboards MUST compliment the theme and be neat and tidy.**
4. The arrangement is to be composed of natural plant material, with or without accessories.

**5. Measurements**

The arrangement must be contained within a space measuring **600mm wide X 600mm deep X optional height**. There is no height limit for the display. Table covering will be in white. Exhibits to be viewed from the front.

Diagram showing width, depth and height, remembering to include thickness of wood or overhanging drapes etc.

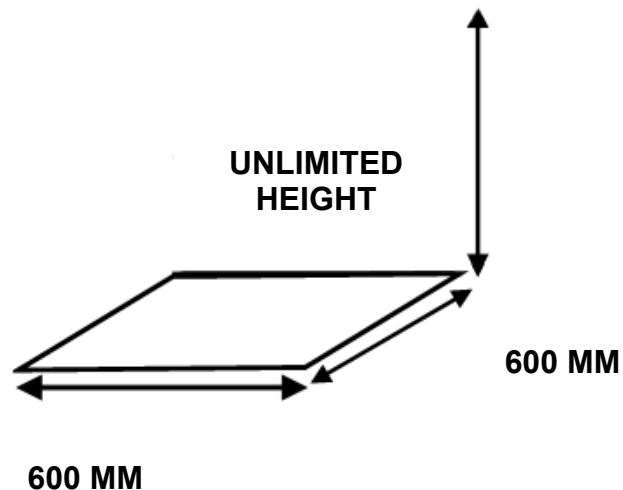

*Just remember – it is better to aim to be 1cm or 1 inch smaller than the size allowed as the size stated is the MAXIMUM size.*

All the work of arranging materials must be carried out at the competition.

6. **All exhibits must be the unaided work of the competitors.** During the period of the competition, competitors must not communicate directly or indirectly with any person other than Judges and Stewards under penalty of instant disqualification. No other person, other than the competitors, will be allowed in the competing area.
7. Competitors must wear clean white coats during the competition.

8. The following scale of marking will be observed:

Idea	20
Colour	20
Composition	20
Technical	40
<b>Total</b>	<b>100</b>

9. No exhibits in any competition may be removed before the prize giving on Saturday 25th May 2018, unless otherwise directed by the Chief Steward. Failure to comply will result in all marks awarded for the competition concerned being removed and the competitors disqualified.

**PLEASE ALSO NOTE THE FOLLOWING:**

- A. ALL EXHIBITS WILL BE JUDGED STRICTLY IN ACCORDANCE WITH THE NAFAS COMPETITIONS MANUAL 2009.** A "Competitions Manual" is available from NAFAS Enterprises Ltd, Osborne House, 12 Devonshire Square, London EC2M 4TE, price £5.00 plus postage. [www.nafas.org.uk](http://www.nafas.org.uk) to visit the NAFAS on-line shop.
- B. NAFAS Definitions (The National Association of Flower Arranging Societies of Great Britain) From the NAFAS Competitors Manual (Second Edition 2009).**
- C. An EXHIBIT:**
- Is composed of natural plant material, with or without accessories, contained within a space as specified in a show schedule.
  - Backgrounds, bases, containers, drapes, exhibit titles and mechanics may always be included in an exhibit, unless otherwise stated.
  - More than one placement may always be included, unless otherwise stated.
  - In all exhibits (except still life) natural plant material **must** predominate.
- D. NATURAL PLANT MATERIAL**
- Natural plant material is any vegetable matter
  - It includes fresh, dried, garden, wild, or made-up plant material flowers, foliage, fruit, fungi, vegetables, seaweed meat (cooked or raw).
  - NOTE: It is acceptable to enhance plant material by the application of oil, milk, wax or other similar products.
- E. An ACCESSORY**
- Anything other than natural plant material in an exhibit, such as, feathers, shapes (spheres, cones), shells, stones, wax candles
  - Natural plant material which has been tooled or crafted to resemble non-plant forms, e.g. birds nest, corn dolly, wooden figurine.
  - Accessories may be decorated in any way but greater credit should be given for the use of natural plant material where appropriate.
  - The following **are not** accessories and may also be used unless prohibited by the show schedule: backgrounds, bases, containers holding plant material, drapes, exhibit titles and mechanics. These may be decorated in any way but greater credit should be given for use of natural plant material where appropriate.
- F. Please also note:**
- REASONS FOR DISQUALIFICATION**
- Failure to comply with any specific requirements of a class as stated in a show schedule, i.e. the measurements or the components. (Just remember – it is better to aim to be 1xm or 1 inch smaller than the size allowed as the size stated is the MAXIMUM size).
  - Inclusion of artificial plant material (unless specifically allowed by a show schedule)
  - Inclusion of fresh plant material that does not have roots or the cut ends of stems in water or water-retaining material. Exceptions: Air Plants, Cacti, Fruits, Grass Turf, Lichen, Moss, Succulents, Vegetables and long lasting plant material which will remain turgid for the duration of a show. (Definition of turgid – the state of firmness of plant tissue resulting from adequate moisture, causing the plant cells to be fully expanded).
- G. NOT ACCORDING TO SCHEDULE DISQUALIFICATION:**
- 'Not according to schedule' is the term used when an exhibit does not comply with the requirements of the schedule – see NAFAS reasons for disqualification above. The judge will write 'Not according to schedule' and the reason.

## Class 23 - Floral Art – Junior

**Date/Time:** Saturday 16<sup>th</sup> June 2019.  
Booking in at **10.45am** ready to start at **11.00am**.

**Entries:** Each Club can make one entry in this competition. Competitors must be **16 years of age or under** on 1<sup>st</sup> September 2018. **Competitors Will Be Required To Show Their Current Membership Cards.**

**Marks:** Maximum of 100 marks towards the SHOW CHAMPIONSHIP CUP  
Maximum of 100 marks towards the VENABLES SHIELD.  
Maximum of 100 marks towards the JUNIOR EVENTS CUP.

### Rules:

1. Maximum time allowed **ONE HOUR** and a further five minutes to check arrangements have not been disturbed during clearing up. Competitors may unpack their equipment and plant material before the hour starts, they may also be able to set up their display area.
2. Each competitor will be required to produce an exhibit to the title: **“My Great Hobby”**
3. Exhibit is to be viewed from the front. Competitors own backboard and base boards are allowed, and must be provided by the competitor if required and must adhere to the size limitations. **The reverse of these backboards MUST compliment the theme and be neat and tidy.**
4. The arrangement is to be composed of natural plant material, with or without accessories.
5. **Measurements**  
The arrangement must be contained within a space measuring **600mm wide X 600mm deep X optional height**. There is no limit to the height of the display. Table covering will be in white. Exhibits to be viewed from the front.

Diagram showing width, depth and height, remembering to include thickness of wood or overhanging drapes etc.

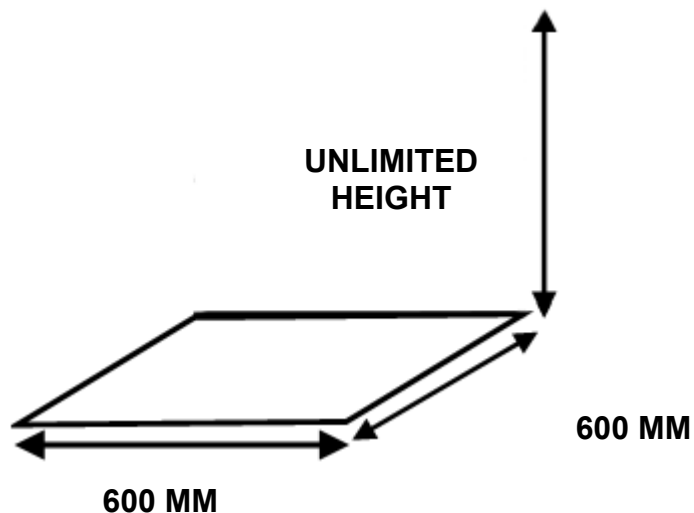

*Just remember – it is better to aim to be 1cm or 1 inch smaller than the size allowed as the size stated is the MAXIMUM size.*

6. All the work of arranging materials must be carried out at the competition.
7. **All exhibits must be the unaided work of the competitors.** During the period of the competition, competitors must not communicate directly or indirectly with any person other than Judges and Stewards under penalty of instant disqualification.
8. Competitors must wear clean white coats during the competition.
9. The following scale of marking will be observed:

Idea	20
------	----

Colour	20
Composition	20
Technical	40
<b>Total</b>	<b>100</b>

10. No exhibits in any competition may be removed before the prize giving on Saturday 25th May 2019, unless otherwise directed by the Chief Steward. Failure to comply will result in all marks awarded for the competition concerned being removed and the competitors disqualified.

**PLEASE ALSO NOTE THE FOLLOWING:**

- A. ALL EXHIBITS WILL BE JUDGED STRICTLY IN ACCORDANCE WITH THE NAFAS COMPETITIONS MANUAL 2009.** A "Competitions Manual" is available from NAFAS Enterprises Ltd, Osborne House, 12 Devonshire Square, London EC2M 4TE, price £5.00 plus postage. [www.nafas.org.uk](http://www.nafas.org.uk) to visit the NAFAS on-line shop.
- B. NAFAS Definitions (The National Association of Flower Arranging Societies of Great Britain) From the NSAFAS Competitors Manual (Second Edition 2009).**
- C. An EXHIBIT:**
- Is composed of natural plant material, with or without accessories, contained within a space as specified in a show schedule.
  - Backgrounds, bases, containers, drapes, exhibit titles and mechanics may always be included in an exhibit, unless otherwise stated.
  - More than one placement may always be included, unless otherwise stated.
  - In all exhibits (except still life) natural plant material **must** predominate.
- D. NATURAL PLANT MATERIAL**  
The button hole exhibit is exempt from the NAFAS rules stating - Inclusion of fresh plant material that does not have roots or the cut ends of stems in water or water-retaining material. Exceptions: Air Plants, Cacti, Fruits, Grass Turf, Lichen, Moss, Succulents, Vegetables and long lasting plant material which will remain turgid for the duration of a show. (Definition of turgid – the state of firmness of plant tissue resulting from adequate moisture, causing the plant cells to be fully expanded) i.e. the button hole does not need to be displayed in water.
- E. AN ACCESSORY**
- Anything other than natural plant material in an exhibit, such as, feathers, shapes (spheres, cones), shells, stones, wax candles
  - Natural plant material which has been tooled or crafted to resemble non-plant forms, e.g. birds nest, corn dolly, wooden figurine.
  - Accessories may be decorated in any way but greater credit should be given for the use of natural plant material where appropriate.
  - The following **are not** accessories and may also be used unless prohibited by the show schedule: backgrounds, bases, containers holding plant material, drapes, exhibit titles and mechanics. These may be decorated in any way but greater credit should be given for use of natural plant material where appropriate.
- F. Please also note:**
- REASONS FOR DISQUALIFICATION**
- Failure to comply with any specific requirements of a class as stated in a show schedule, i.e. the measurements or the components. (Just remember – it is better to aim to be 1xm or 1 inch smaller than the size allowed as the size stated is the MAXIMUM size).
  - Inclusion of artificial plant material (unless specifically allowed by a show schedule)
- Inclusion of fresh plant material that does not have roots or the cut ends of stems in water or water-retaining material. Exceptions: Air Plants, Cacti, Fruits, Grass Turf, Lichen, Moss, Succulents, Vegetables and long lasting plant material which will remain turgid for the duration of a show. (Definition of turgid – the state of firmness of plant tissue resulting from adequate moisture, causing the plant cells to be fully expanded).
- G. NOT ACCORDING TO SCHEDULE DISQUALIFICATION:**  
'Not according to schedule' is the term used when an exhibit does not comply with the requirements of the schedule – see NAFAS reasons for disqualification above. The judge will write 'Not according to schedule' and the reason.

## Class 24 - Cookery – Boys Cookery

**Date/Time:** Saturday 25th May 2019.  
Booking in at **10.45am** ready to start at **11.00am**.

**Entries:** Each Club can make one entry in this competition. Competitors must be **Male**, and must be **26 years of age or under** on 1<sup>st</sup> September 2018. **Competitors Will Be Required To Show Their Current Membership Cards.**

**Marks:** Maximum of 100 marks towards the SHOW CHAMPIONSHIP CUP.  
Maximum of 100 marks towards the VENABLES SHIELD.

### **Rules:**

1. Maximum time allowed **ONE HOUR**
2. Each competitor will be required to prepare and display to the best advantage in a space not exceeding **680mm x 680mm**, a **DISH** for two people to the theme **"Honeymoon Brunch"**
3. A "dish" is required to serve two people and may include more than one item, which form a total. Accessories to be kept to a minimum. There are no limitations on the contents of the display, although **Competitors must display a menu card, details of recipes and costing**. Recipes must be available throughout the practical session. Judges will place emphasis on marking displays that compliment the dishes.
4. **NO Deep Fat Frying Allowed.**
5. Two (2) butane gas stoves will be provided.  
No other heat is allowed; this includes blowtorches and similar equipment. Electricity is not available.  
  
Competitors will be required to provide:  
a) All equipment other than tables & gas stoves.  
b) All ingredients (these may be brought to the competition already weighed out and vegetables ready washed).
6. The following scale of marking will be observed:

Workmanship (Hygiene, Safety, Time Management & Practical Skills)	35
Finished dishes, suitability and variety	15
Taste	25
Overall display & interpretation of theme	15
Menu Card including recipe & costings	10
<b>Total</b>	<b>100</b>

7. Competitors must wear clean white coats during the competition.
8. The competitor as directed by the Judge must cover the dish with cling film.
9. No exhibits in any competition may be removed before the prize giving on Saturday 25th May 2019, unless otherwise directed by the Chief Steward. Failure to comply will result in all marks awarded for the competition concerned being removed and the competitors disqualified.

### **Please Note:**

- A. Many county federations will wish to or do already use these stoves at the county round of the competition and the following safety advice is given: -
  - The event organiser should nominate a Safety Officer who should be on-site for the duration of the setting up and one-hour preparation and cooking time.
- B. He should Check the stove's condition before each use, if the gas canister seal looks damaged, or if the stove or gas canister is extremely rusty and deteriorated, it must not be used.
- C. Ensure all competitors are familiar with the operating instructions for the stove and are confident at igniting it, regulating the flame and turning the stove off.

- D. Check the pan support and spill tray – on some models these must be turned over after removal from the carry case, to the correct cooking position.
  - a) If the pan support is upside down and the burner is used, heat can be transferred onto the aerosol type butane canister in the body of the stove and after a time, the canister can burst causing a violent fire.
- E. Ensure that the correct type of gas canister for the appliance is used and that it is correctly fitted (in the right place and in the right way).
- F. When fitting the butane canister, do not force the gas canister-retaining lever into position as this can damage the mechanical linkage and the safety pressure relief device.
  - a) If there is a problem with the retaining lever, check that the pan support and spill tray and the butane gas canister has been correctly fitted.
  - b) If there is still a problem with the lever or if there are further problems or concerns, do not attempt to ignite the stove.
- G. If anyone smells or hears gas leaking from the stove before attempting to light it, **don't use it & inform an official.**
- H. If any gas is leaking, ensure that it is being dispersed in free air well away from any sparks or other sources of ignition.



## Class 25 - Woodwork

**Date/Time:** Saturday 25th May 2019  
Booking in at **8.30am** ready to start at **8.45am**

**Entries:** Each Club may **enter one team**. A team will consist **TWO members** in this competition. Competitors must be **26 years of age or under** on 1<sup>st</sup> September 2018. **Competitors Will Be Required To Show Their Current Membership Cards.**

**Marks:** Maximum of 200 marks towards the SHOW CHAMPIONSHIP CUP.  
Maximum of 200 marks towards the VENABLES SHIELD.  
Maximum of 200 marks towards the Woodwork Tankard

### **Rules:**

1. Each team will be required to construct a **“Bird Table”** of their own design within the rules as set out below. **Maximum size: 500mm in Depth x 500mm in Width x 1800mm height.**
2. Time allowed: 2hrs 30min.  
Competitors that are over the allotted time will be penalised by the deduction of 1 mark for every 1 minute or part thereof over time, up to an additional 15minutes. In this time the competitors **MUST** produce a product in a finished state.
3. Clubs to provide all required wood, fixings and tools to complete.
4. Consideration should be given to the safe use of the Bird Table, and consideration should be given to weather proofing.
5. The bird table should be predominantly made from timber but accessories deemed necessary by the competitors for the construction will be allowed.
6. No work or marking out to be done beforehand.
7. Teams to supply their own tools. **Chainsaws, nail-guns and circular saw are NOT allowed (including battery powered versions of these).** Battery and rechargeable electric power tools will be allowed, **but must be operated by a club member over the age of 18.** Stewards will stop any competitor from continuing if they feel the use of tools is deemed unsafe. No power supply will be provided.
8. Teams must wear suitable personal protective clothing (PPE).
9. Teams must provide a ground sheet for their work area and will be responsible for clearing up when they have finished construction. Teams that are unable to provide a groundsheet will not be able to compete and will be disqualified.
10. No names of clubs or counties to be marked on any exhibits.
11. The following scale of marking will be observed:

Design	60
Construction	80
Finish and Aesthetics	40
Time Management	10
Work Area Safety & Tidiness	10
<b>Total</b>	<b>200</b>

12. No exhibits in any competition may be removed before the prize giving on Saturday 25th May 2019, unless otherwise directed by the Chief Steward. Failure to comply will result in all marks awarded for the competition concerned being removed and the competitors disqualified.
13. Teams are responsible for removing the finished item at the end of the show.

## **Class 26 - Auctioneering**

**Date/Time:** Saturday 25th May 2019  
Booking in at 11.15am ready to start at **11.30am**

**Entries:** Each Club can make one entry in this competition. Competitors must be **26 years of age or under** on 1<sup>st</sup> September 2018. **Competitors Will Be Required To Show Their Current Membership Cards.**

**Marks:**

**Rules:**

1. Each competitor will be required to auction 3 lots.
2. Prior to the auction commencing, competitors will view a total of 6 items – lots will include agricultural & non-agricultural items. Competitors will then have 20 minutes to draft a hand-written, catalogue-style description, and provide a valuation figure for each item on the day of the competition.
3. The competitor is to hand their valuations and descriptions to the judge prior to the auction. The judge will choose 3 out of the 6 items, for the competitor to auction. The judge will identify one of the items to have a reserve – the item and price of the reserve lot is at the judge's discretion.
4. The competitor should provide an introduction to open the auction sale, outlining the procedure and conditions of the sale, eg. the payment process, order of the auction, buyers commission rate.
5. Competitors will not be able to watch other competitors, before they have competed themselves.
6. Stewards will be placed in the audience to act as purchasers on the lots to ensure there is enough bidding to enable the competitor to demonstrate the skill. These stewards will be anonymous to the competitor and will only bid if no other bids are forthcoming. Stewards will have no knowledge of the valuations provided by the competitor.
7. Once all of the lots have been 'sold' the auctioneer will close the auction in a suitable way and the judge will work out their score.
8. The following scale of marking will be observed:

Lot Description & Valuation	20
Opening & Closing Commentary	20
Auctioneering Skill	40
Auction Conduct & Practice	20
<b>Total</b>	<b>100</b>

## Class 27 - Cookery – Intermediate

**Date/Time:** Saturday 25th May 2019.  
Booking in at **1.30pm** ready to start at **1.45pm**.

**Entries:** Each Club can make one entry in this competition. Competitors must be **21 years of age or under** on 1<sup>st</sup> September 2018. **Competitors Will Be Required To Show Their Current Membership Cards.**

**Marks:** Maximum of 200 marks towards the SHOW CHAMPIONSHIP CUP.  
Maximum of 200 marks towards the VENABLES SHIELD  
Maximum of 200 marks towards the JUBLIEE CUP.

### **Rules:**

1. Maximum time allowed **ONE HOUR**.
2. Each competitor will be required to prepare and display to the best advantage in a space not exceeding **680mm x 680mm**, a **Main** for two people to the theme **"Rare Breeds Survival Trust Gala Dinner"**.
3. A "dish" is required to serve two people and may include more than one item, which form a total. Accessories to be kept to a minimum. There are no limitations on the contents of the display, although **Competitors must display a menu card, details of recipes and costing**. Recipes must be available throughout the practical session. Judges will place emphasis on marking displays that complement the dishes.
4. **NO Deep Fat Frying Allowed.**
5. Two (2) butane gas stoves will be provided.  
No other heat is allowed; this includes blowtorches and similar equipment. Electricity is not available.  
  
Competitors will be required to provide:  
a) All equipment other than tables & gas stoves.  
b) All ingredients (these may be brought to the competition already weighed out and vegetables ready washed).
6. The following scale of marking will be observed:

Workmanship (Hygiene, Safety, Time Management & Practical Skills)	35
Finished dishes, suitability and variety	15
Taste	25
Overall display & interpretation of theme	15
Menu Card including recipe & costings	10
<b>Total</b>	<b>100</b>

7. Competitors must wear clean white coats during the competition.
8. The competitor as directed by the Judge must cover the dish with cling film.
9. No exhibits in any competition may be removed before the prize giving on Saturday 25th May 2019, unless otherwise directed by the Chief Steward. Failure to comply will result in all marks awarded for the competition concerned being removed and the competitors disqualified.

### **Please Note:**

- A. Many county federations will wish to or do already use these stoves at the county round of the competition and the following safety advice is given: -
  - The event organiser should nominate a Safety Officer who should be on-site for the duration of the setting up and one-hour preparation and cooking time.
- B. He or she should Check the stove's condition before each use, if the gas canister seal looks damaged, or if the stove or gas canister is extremely rusty and deteriorated, it must not be used.

- C. Ensure all competitors are familiar with the operating instructions for the stove and are confident at igniting it, regulating the flame and turning the stove off.
- D. Check the pan support and spill tray – on some models these must be turned over after removal from the carry case, to the correct cooking position.

If the pan support is upside down and the burner is used, heat can be transferred onto the aerosol type butane canister in the body of the stove and after a time, the canister can burst causing a violent fire.

- E. Ensure that the correct type of gas canister for the appliance is used and that it is correctly fitted (in the right place and in the right way).
- F. When fitting the butane canister, do not force the gas canister-retaining lever into position as this can damage the mechanical linkage and the safety pressure relief device.

If there is a problem with the retaining lever, check that the pan support and spill tray and the butane gas canister has been correctly fitted.

If there is still a problem with the lever or if there are further problems or concerns, do not attempt to ignite the stove.

- G. If anyone smells or hears gas leaking from the stove before attempting to light it, **don't use it & inform an official.**
- H. If any gas is leaking, ensure that it is being dispersed in free air well away from any sparks or other sources of ignition.

## Class 28 - Obstacle Race on Skis

**Date/Time:** Saturday 25th May 2019.  
Booking in at **11.45am** ready to start at **12.00pm**.

**Entries:** Each Club can make one entry in this competition. An entry consists of a teams **of a THREE** members all to be **26 and under** on 1<sup>st</sup> September 2018. **Competitors Will Be Required To Show Their Current Membership Cards.**

**Marks:** Maximum of 100 marks towards the SHOW CHAMPIONSHIP CUP.  
Maximum of 100 marks towards the AFTERNOON EVENTS CUP.

**Rules:**

1. Competitors will be required to complete an obstacle course on skis to the theme of **“Ski Holiday”**.  
  
All teams will need to make and provide all required equipment and helmets.
2. All teams will be judged on their decorative skis and costumes relevant to the theme.
3. A grassed area of 25 x 20m will be supplied and teams are required to go around a course of obstacles.
4. The time taken for teams to complete the course will be recorded in case of a tie break situation.

The following scale of marks will be observed for the race:

First placed team	30
Second placed team	25
Third placed team	20
Forth placed team	15
Fifth placed team	10
Sixth placed team	5

5. The following scale of marking will be observed:

Theme	15
Dress	15
Build	40
Race points (Maximum)	30
<b>Total</b>	<b>100</b>

## Class 29 - Highland Fling Dance

**Date/Time:** Saturday 25th May 2019.  
Booking in at **11.45am** ready to start at **12.00pm**.

**Entries** Each Club can make one entry in this competition. An entry consists of Minimum of Two and Maximum of Six Member who must be **26 years of age or under** on 1<sup>st</sup> September 2018.  
**Competitors Will Be Required To Show Their Current Membership Cards.**

**Marks:** Maximum of 100 marks towards the SHOW CHAMPIONSHIP CUP.

### **Rules:**

1. Competitors are required to perform a **“Highland Fling”**.
2. Competitors to provide their own music and accessories.
3. The Highland fling must be suitable for a family audience.
4. A carpeted **staged** area of **6m x 6m and 2.5m high and set 1 foot off the ground approximately**.
5. The show has to be a **minimum of 2 minutes and a maximum of 6 minutes** in length. Time penalties of one mark per thirty seconds or part thereof outside of this time. This does not include setting and dismantling of stage.
6. The following scale of marking will be observed:

Creativity of dance	30
Use of costumes	20
Originality	20
Overall Effect	30
Total	100

## Class 30- Cookery – Senior

**Date/Time:** Saturday 25th May 2019.  
Booking in at **9.15am** ready to start at **9.30am**.

**Entries:** Each Club can make one entry in this competition. Competitors must be **26 years of age or under** on 1<sup>st</sup> September 2018. **Competitors Will Be Required To Show Their Current Membership Cards.**

**Marks:** Maximum of 100 marks towards the SHOW CHAMPIONSHIP CUP.  
Maximum of 100 marks towards the VENABLES SHIELD.  
Maximum of 100 marks towards the JUBILEE CUP.

**Rules:**

1. Maximum time allowed **ONE HOUR**.
2. Each competitor will be required to prepare and display to the best advantage in a space not exceeding **680mm x 680mm**, a **STARTER** for two people to the theme **"Rare Breeds Survival Trust Gala Dinner"**.
3. A "dish" is required to serve two people and may include more than one item, which form a total. Accessories to be kept to a minimum. There are no limitations on the contents of the display, although **Competitors must display a menu card, details of recipes and costing**. Recipes must be available throughout the practical session. Judges will place emphasis on marking displays that compliment the dishes.
4. **NO Deep Fat Frying allowed.**
5. Two (2) butane gas stoves will be provided.  
No other heat is allowed; this includes blow torches and similar equipment. Electricity is not available.

Competitors will be required to provide:

- a) All equipment other than tables & gas stoves.
- b) All ingredients (these may be brought to the competition already weighed out and vegetables ready washed).

6. The following scale of marking will be observed:

Workmanship (Hygiene, Safety, Time Management & Practical Skills)	35
Finished dishes, suitability and variety	15
Taste	25
Overall display & interpretation of theme	15
Menu Card including recipe & costings	10
<b>Total</b>	<b>100</b>

7. Competitors must wear clean white coats during the competition.
8. The dish must be covered with cling film by the competitor as directed by the Judge.
9. No exhibits in any competition may be removed before the prize giving on Saturday 25th May 2019, unless otherwise directed by the Chief Steward or Chairman of the YFC Section. Failure to comply will result in all marks awarded for the competition concerned being removed and the competitors disqualified.

**Please Note:**

- A. Many county federations will wish to or do already use these stoves at the county round of the competition and the following safety advice is given:-
  - The event organiser should nominate a Safety Officer who should be on-site for the duration of the setting up and one hour preparation and cooking time.
- B. Check the stove's condition before each use, if the gas canister seal looks damaged, or if the stove or gas canister is extremely rusty and deteriorated, it must not be used.

- C.** Ensure all competitors are familiar with the operating instructions for the stove and are confident at igniting it, regulating the flame and turning the stove off.
- D.** Check the pan support and spill tray – on some models these must be turned over after removal from the carry case, to the correct cooking position.  
If the pan support is upside down and the burner is used, heat can be transferred onto the aerosol type butane canister in the body of the stove and after a time, the canister can burst causing a violent fire.
- E.** Ensure that the correct type of gas canister for the appliance is used and that it is correctly fitted (in the right place and in the right way).
- F.** When fitting the butane canister, do not force the gas canister retaining lever into position as this can damage the mechanical linkage and the safety pressure relief device.

If there is a problem with the retaining lever, check that the pan support and spill tray and the butane gas canister has been correctly fitted.

If there is still a problem with the lever or if there are further problems or concerns, do not attempt to ignite the stove.
- G.** If anyone smells or hears gas leaking from the stove before attempting to light it, **don't use it & inform an official.**
- H.** If any gas is leaking, ensure that it is being dispersed in free air well away from any sparks or other sources of ignition.



## Class 31 - Holiday Rep Variety Performance

**Date/Time:** Saturday 25th May 2019.  
Booking in at **9.15am** ready to start at **9.30am**.

**Entries** Each Club can make one entry in this competition. An entry consists of a **team Maximum of Five Minimum of Two** competitors, all of whom must be **26 years of age or under** on 1<sup>st</sup> September 2018. **Competitors Will Be Required To Show Their Current Membership Cards.**

**Marks** Maximum of 100 marks towards the SHOW CHAMPIONSHIP CUP.

**Rules:**

1. Each team will need to perform a sketch to the theme **“Holiday Rep Variety Performance”**.
2. The size of the dance area will be a **staged area 6m x 6m**.
3. Under no circumstances must any team use overhead lifts/tumbling, pyramids, throws or any other move that should jeopardise the safety of themselves or others
4. Stage time not to exceed **TEN minutes** in duration. This includes setting and dismantling of the stage. Time penalties of one mark per thirty seconds or part thereof above this time.
5. The following scale of marking will be observed:

Variety	30
Technical Marks	30
Costume	20
Overall Presentation	20
Total	100

**Class 32, 33, 34, 35, & 36**  
**See Stock-judging Rule Book**

## Class 37 - Cookery – Junior

**Date/Time:** Saturday 25th May 2019.  
Booking in at **12.15pm** ready to start at **12.30pm**.

**Entries:** Each Club can make one entry in this competition. Competitors must be **16 years of age or under** on 1<sup>st</sup> September 2018. **Competitors Will Be Required To Show Their Current Membership Cards.**

**Marks:** Maximum of 100 marks towards the SHOW CHAMPIONSHIP CUP.  
Maximum of 100 marks towards the VENABLES SHIELD.  
Maximum of 100 marks towards the JUNIOR EVENTS CUP.

**Rules:**

1. Maximum time allowed **ONE HOUR**.
2. Each competitor will be required to prepare and display to the best advantage in a space not exceeding **680mm x 680mm**, a **Dessert** for **TWO** people to the theme **"Rare Breeds Survival Trust Gala Dinner"**.
3. A "dish" is required to serve two people and may include more than one item, which form a total. Accessories to be kept to a minimum. There are no limitations on the contents of the display, although **Competitors must display a menu card, details of recipes and costing**. Recipes must be available throughout the practical session. Judges will place emphasis on marking displays that compliment the dishes.
4. **NO** Deep Fat Frying allowed.
5. Two (2) butane gas stoves will be provided.  
No other heat is allowed; this includes blow torches and similar equipment. Electricity is not available.

Competitors will be required to provide:

All equipment other than tables & gas stoves.

All ingredients (these may be brought to the competition already weighed out and vegetables ready washed).

6. The following scale of marking will be observed:

Workmanship (Hygiene, Safety, Time Management & Practical Skills)	35
Finished dishes, suitability and variety	15
Taste	25
Overall display & interpretation of theme	15
Menu Card including recipe & costings	10
<b>Total</b>	<b>100</b>

7. Competitors must wear clean white coats during the competition.
8. The dish must be covered with cling film by the competitor as directed by the Judge.
9. No exhibits in any competition may be removed before the prize giving on Saturday 25th May 2019, unless otherwise directed by the Chief Steward or Chairman of the YFC Section. Failure to comply will result in all marks awarded for the competition concerned being removed and the competitors disqualified.

**Please Note:**

- A. Many county federations will wish to or do already use these stoves at the county round of the competition and the following safety advice is given:

The event organiser should nominate a Safety Officer who should be on-site for the duration of the setting up and one hour preparation and cooking time.

- B.** Check the stove's condition before each use, if the gas canister seal looks damaged, or if the stove or gas canister is extremely rusty and deteriorated, it must not be used.
- C.** Ensure all competitors are familiar with the operating instructions for the stove and are confident at igniting it, regulating the flame and turning the stove off.
- D.** Check the pan support and spill tray – on some models these must be turned over after removal from the carry case, to the correct cooking position.
- If the pan support is upside down and the burner is used, heat can be transferred onto the aerosol type butane canister in the body of the stove and after a time, the canister can burst causing a violent fire.
- E.** Ensure that the correct type of gas canister for the appliance is used and that it is correctly fitted (in the right place and in the right way).
- F.** When fitting the butane canister, do not force the gas canister retaining lever into position as this can damage the mechanical linkage and the safety pressure relief device.
- If there is a problem with the retaining lever, check that the pan support and spill tray and the butane gas canister has been correctly fitted.
- If there is still a problem with the lever or if there are further problems or concerns, do not attempt to ignite the stove.
- G.** If anyone smells or hears gas leaking from the stove before attempting to light it, **don't use it & inform an official.**
- H.** If any gas is leaking, ensure that it is being dispersed in free air well away from any sparks or other sources of ignition.

## Class 38 - Parody Song

**Date/Time:** Saturday 25th May 2019.  
Booking in at **12.45pm** ready to start at **13.00pm**.

**Entries:** Each Club can make one entry in this competition. An entry consists of a minimum of **TWO** and maximum of **FOUR** members. Competitors must be **26 years of age or under** on 1<sup>st</sup> September 2018. **Competitors Will Be Required To Show Their Current Membership Cards.**

**Marks:** Maximum of 100 marks towards the SHOW CHAMPIONSHIP CUP.

**Rules:**

1. Each team will need to perform a **“Parody Song”** For completion of the song, competitors can use backing track if they wish and has to be a **minimum of 2 minutes and a maximum of 5 minutes** in length. Time penalties of one mark per thirty seconds or part thereof outside of this time. This does include setting and dismantling of stage.
2. The performance area will be on the Main Stage .
3. For completion of the song teams have a maximum of **five minutes and a minimum of two minutes**.
4. The following scale of marking will be observed:

Creativity	25
Variety	25
Costume	25
Overall Presentation	25
Total	100

## Class 39 - Soapbox Race

**Date/Time:** Saturday 25th May 2019.

Booking in **13.15pm** ready to start at **13.30pm**.

**Completed Soapboxes will be required at the showground Friday 24th May to display prior to and after the competition.**

**Entries:** Each Club can make one entry in this competition. An entry consists of a **team of THREE** members. Competitors must be **26 years of age or under** on 1<sup>st</sup> September 2018. **Competitors Will Be Required To Show Their Current Membership Cards.**

**Marks:** Maximum 100 per entry towards the SHOW CHAMPIONSHIP CUP.

**Rules:**

1. Each team will be required to race an **“Ice Cream Soapbox”**, which is to be made by the competitors beforehand. The soapbox is to be decorated in an Ice Cream Van theme.
2. Two members will race the soapbox around a designated obstacle course, whilst the third member remains in the soapbox. This member must wear a safety helmet and suitable protective equipment
3. All team members must be dressed in accordance with the theme.
4. The soapbox must be capable of carrying at least one person.
5. Any soapbox deemed unsafe by the judge/Chief Steward will not be allowed to race.
6. The soapbox will be raced in the main arena at the Showground, which is a grassed area of approximately 70 x 120m.
7. The time taken for teams to complete the course will be recorded in case of a tie break situation.
8. The following scale of marks will be observed for the race:

First placed team	30
Second placed team	25
Third placed team	20
Forth placed team	15
Fifth placed team	10
Sixth placed team	5

9. The following scale of marking will be observed:

Theme	15
Dress	15
Build	40
Race points (Maximum)	30
<b>Total</b>	<b>100</b>

10. Use of the soapbox around the showground will not be permitted.

## Class 40 & 41 - Tug of War – Mixed Juniors

**Date/Time:** Saturday 25th May 2019.

**Booking in and weigh in for JUNIOR commences at 1.00pm.**

Pulling times 3.00pm

**Entries:** **Class 42.** Three Counties competition is open to Gloucestershire, Herefordshire and Worcestershire who may each enter one team. A team shall consist of between 7 and 10 pulling members male or female who must be between the ages of 12 years of age and over & 17 years of age and under on 1<sup>st</sup> September 2018. **This means competitors MUST have attained their 12<sup>th</sup> birthday on 1<sup>st</sup> September 2018 and may be 18 on the day of the competition.** (You cannot compete for more than one club and county in one membership year)

**Class 43.** This competition is open to all Clubs each team to consist of 7 to 10 members as above. A team shall consist of between 7 and 10 pulling members male or female who must be between the ages of 12 years of age and over & 17 years of age and under on 1<sup>st</sup> September 2018. **This means competitors MUST have attained their 12<sup>th</sup> birthday on 1<sup>st</sup> September 2018 and may be 18 on the day of the competition.** (You cannot compete for more than one club and county in one membership year)

**Competitors Will Be Required To Show Their Current Membership Cards.**

**Competitors Will Be Required To Present a Signed Parental Consent Form to obtain a wristband.**

**Competitors must sign in with a membership card, parental consent form, boots and full team. Any teams not present with all of the above will be sent away and need to queue again when all the above are present.**

**Marks:** Tug of War trophies

**Rules:**

1.

### **ELIGIBILITY**

Note the weighing in procedure and weight bonus overleaf for the inclusion of female pullers. There is no limit on the number of males or number of females in the team (may be all male, all female or any combination of male and female).

**Coaches and Trainers** – Only one Coach is permitted with each team during pulling. Only one Trainer or "Water-Carrier" is permitted with each team. During pulling the Trainer shall take up position well clear of both teams and is not permitted to address any remark to them during actual pulling. Neither the Coach nor Trainer need comply with other rules of eligibility.

Competitors are required *in person* to produce on the day of the competition their current and signed Membership Card, with suitable photograph, or a fine of **£20** will be imposed for non-production.

2.

### **WEIGHING-IN PROCEDURE AND WEIGHT LIMITS**

The members of the team will be weighed as one and will not exceed: 560kg , GENSB rules.

'Lining up women in the team will give a bonus of 10 kg for each on the weight allowance, limited to a maximum team weight of 600 kg'

The competitors will be stamped or marked on a limb in a position easily seen by the Judge, but not easily erased by the rope or competitors clothing.

**At weigh-in all team members must have their boots available for inspection by the judges.**

3.

### **PULLING**

Each team shall pull a match of 2 ends against every other team in the league with points awarded as follows:

- |            |  |
|------------|--|
| 3 points   | to the winners in a straight pull (two straight pulls) |
| Nil points | to the losers in a straight pull                       |
| 1 point    | to each team winning 1 pull each                       |

If there is one league; the top 4 teams on points shall enter the semi-final competition as follows: 1<sup>st</sup> v 4<sup>th</sup>; 2<sup>nd</sup> v 3<sup>rd</sup>

If there are two leagues; the top 2 teams on points from each league shall enter the semi-final competition as follows: League one winner v League two runner up    League two winner v League one runner up

The losers of the semi-finals shall pull off for 3<sup>rd</sup> and 4<sup>th</sup> places before the winners of the semi-finals pull off for 1<sup>st</sup> and 2<sup>nd</sup> places.

**The semi-finals, 3<sup>rd</sup>/4<sup>th</sup> pull off and the final matches shall be won by two (2) pulls out of three (3).**

If teams are drawing on points at the end of the league; they shall be ranked using the following system:

**Results of matches (between the teams drawing on points).**

**Matches won (most matches won).**

**Cautions (least number throughout pulling).**

**Team weight (lowest team weight at weigh in).**

**Coin toss or draw.**

#### 4. **SUBSTITUTION**

After a team has pulled the first end of the first match, the team is able to use a substitution. A substitute may replace any one puller for the duration of the competition (Age restriction of team still applies). After the substitution has taken place, no other such changes may occur. Substitution may be used for tactical reasons or due to injury.

The substitute must have been signed in with the team at weigh in and have been stamped with a mark. **All substitutes must have been members of the county at the time of the County Final;** and produced their current, signed Membership Card, with suitable photograph, or a fine of £20 will be imposed for non-production.

At the time of substitution; both, the puller to be replaced and the substitute, must report in full pulling outfit, (shirts, shorts, stockings and footwear) to the Chief Judge/Chief Steward who may designate an official to deal with the substitutes. A small (bathroom type) scale must be available at the pulling area, (in a suitable place, on solid surface), to determine the weight difference between the two pullers. The substitute puller must be of equal weight or less than the puller he/she replaces. Directly after the change, the Chief Judge or designated official shall cancel the stamp or marking of the replaced puller, and indicate a similar marking on the substitute, with an indelible marker. This change shall then be recorded.

5. **BOOTS AND SHOES – Competitors' boots must not be "faked" in any way, i.e. THE SOLE HEEL AND SIDE OF THE HEEL SHALL BE PERFECTLY FLUSH – THIS MEANS THE SOLES MUST BE SMOOTH.** No metal toecaps or metal toe-plates are permitted. Metal heel tips that are flush on the side and the bottom of the heel are permitted – this means that tips on the bottom of the heel must be smooth. If teams do not adhere to this they will be disqualified. See example below:

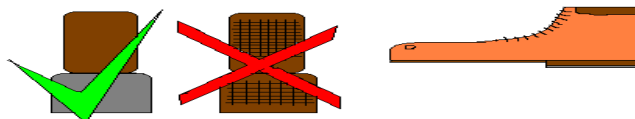

6. **ROPE** - The rope shall not be less than 4" and not more than 5" in circumference (10 cm minimum, 12½ cm maximum) without knots or other holding for the hands and the minimum length not less than 35 yards (32 metres).

7. **ROPE MARKINGS** - Five tapes or markings shall be affixed to the rope as follows: -
- A red tape or marking at the centre of the rope, which will be level with the ground mark at the start of every pull.
  - Two white tapes or markings each 4 metres either side of the red centre tape or marking
  - Two blue tapes or markings each 5 metres either side of the red centre tape or marking.
- The first puller in each team shall grip the rope within 30 cm of these outer blue tapes or markings.

The white and two outer coloured markings shall be capable of easy adjustment by the Judge in the event of the rope shrinking or stretching.

8. **GROUND MARKINGS** - One line shall be marked on the ground at right angles to where the centre of the rope will be at the start of the competitions.
9. **KNOTS OR LOOPS** - No knots or loops may be made in the rope nor may it be locked across any part of the body by any member of a team. Crossing the rope over itself constitutes a loop.
10. **LOCKS** - From the start the rope shall be taut. Every pulling member shall hold the rope with both hands by the ordinary grip and the rope shall pass under the armpit. Any other hold, which prevents the free movement of the rope, is a lock and is an infringement of the Rules.
11. **ANCHOR-MAN'S GRIP**
  - i) Upon taking up position the anchorman will place the rope around his/her body in the approved manner for the inspection of the Judge or his assistant.
  - ii) The approved manner will be:  
The rope will pass under one armpit diagonally across the back and over the opposite shoulder from rear to front. The remaining rope shall pass in a backward and outward direction and the slack shall run free. He/she shall grip the standing part of the rope with both arms extended forward.
12. **THE START** - When the Judge has received the sign from the two coaches that all is ready, he shall give the teams the following verbal commands:
  - **'Pick up the Rope'** - at the same time extending his arms forward and horizontally. The rope shall be held as defined in paragraphs 16 and 17, the feet being flat on the ground.
  - **'Take the Strain'** - at the same time raising both hands above the head (sufficient strain shall be put on the rope to ensure that it is taut and each man may establish one foothold with the heel or side of the boot of the extended foot) - and when the rope is steady with the centre mark over the centre line on the ground - **PULL** - at the same time flinging both arms downwards.
13. **LEAVING GO OF THE ROPE** - In the event of both teams leaving go the rope before a side tape has been pulled over the side ground farthest from it, **'No Pull'** shall be declared and the pull shall not constitute on the requisite on that heat.
14. **WINNING A PULL** - A 'Pull' shall be won when one of the side markings on the rope is pulled over the centre line.
15. **FINISH A PULL** - The finish of a pull shall be signalled by the Judge blowing a whistle and pointing in the direction of the team winning the Pull.
16. **THE JUDGE** - There shall be one Judge who shall have sole control with power to appoint assistants. He shall be responsible for the Rules of the Competition being adhered to. He has the power to: grant reasonable rest periods between pulls and a minimum of six minutes rest to each team between rounds of any competition. To award 'No Pull' in the event of both teams being guilty of infringement (in such cases the pull will be re-taken immediately with no rest period or welfare to competitors being permitted) and to disqualify a team or teams after caution, or disqualify without caution for any offence against the Rules. In the event of a team being disqualified the pull will be awarded to the opposite side.

**NOTE** A team will be deemed guilty of any infringement even though only one member offends. Should it be necessary to caution a team for any infringement of the Rules, the Judge shall, in addition to naming the team and calling 'first caution' or 'last caution' also signal such caution by raising his arm to the horizontal position and pointing in the direction of the offenders. Only two official cautions shall be given during any one pull. Any team guilty of any offence meriting a caution after already having received two official cautions in any one pull will be disqualified.
17. **INFRINGEMENT DURING CONTESTS**



- **Sitting** - deliberately sitting on the ground, or failure to return immediately to the pulling position.
- **Leaning** - touching the ground with any part of the body other than the feet.
- **Locking the Rope** - no knots or loops shall be made in the rope, nor shall it be locked across any part of the body or any member of the team. Crossing the rope over itself constitutes a loop.
- **Grip** - any grip other than the ordinary grip as described above.
- **Propping** - holding the rope in a position where it does not pass between the body and the upper part of the arm.
- **Position** - sitting on a foot or limb or the feet not extended forward of the knee.
- **Climbing the rope** - passing the rope through the hands
- **Rowing** - repeatedly sitting on the ground whilst the feet are moved backwards.
- **Anchor Man's Grip** - any grip other than described in above.
- **Footholds** - making indents in the ground in any way before the command "Take the Strain" is given. Thus cleaning the ground by foot or hand is prohibited.

**18. BEHAVIOUR** - There shall be no conduct by word or act likely to bring the sport into disrepute. No member of a team, i.e. coach, trainer or puller, may address any remark to the Judge whilst pulling is in progress. The use of water, for any purpose, is prohibited within the immediate vicinity of the rope. The function of the trainer is to attend to the requirements of the team before, between, and after pulls; he must not speak to his team during a pull. Assistant Judges shall at all times act under the direction of the Judge and shall be responsible to him for inspection of competitors' footwear, checking the ground and rope markings, the laying out of the rope before a competition and its re-alignment after each pull. During actual pulling, each Assistant Judge shall be in a position alongside the competing teams on the opposite side of the rope to the Judge. An Assistant Judge shall not address any remark to the coach or any member of the team unless he is signaled to do so by the Judge. In the event of the Judge signals a caution, the Assistant Judge shall inform the offenders, naming the team and adding 'first caution' or 'last caution'. Any instructions of the Judge conveyed by the Assistant Judge to a team must be clear and brief.

**19.** The Winner of the West Midland Area Eliminator will go on to the National Final.

## Class 42, 43, 44 & 45 - Tug of War – Ladies & Men's

**Date/Time:** Saturday 25th May 2019.

**Booking in and weigh in for Ladies commences at 1.00pm.**

**Booking in and weigh in for Men commences at 1.00pm.**

Pulling times 3.00pm.

### **Entries: Classes 44 & 46**

Three Counties competition is open to Gloucestershire, Herefordshire and Worcestershire only. Who may enter ONE team. Each team to consist of eight pulling members. No more than **two (2)** members of a team may be between the ages of 15 and under 17 years on 1<sup>st</sup> September 2018 and the remainder of the team **MUST** be between 17 years and 26 years of age or under on 1<sup>st</sup> September 2018. Competitors Will Be Required to Show Their Current Membership Cards.

### **Classes 45 & 47**

The competition is open to Counties throughout the West Midland Area who may enter ONE team per 600 members. Each team to consist of eight pulling members. No more than **two (2)** members of a team may be between the ages of 15 and under 17 years on 1<sup>st</sup> September 2018 and the remainder of the team **MUST** be between 17 years and 26 years of age or under on 1<sup>st</sup> September 2018. Competitors Will Be Required To Show Their Current Membership Cards.

**Competitors Will Be Required To Sign in with Their Current Membership Cards With A Second Form Of Identification To Match, e.g. Driving License or Passport and A Parental Consent Form For Those Under 18.**

**Competitors will be required to weigh in with a membership card, plus second form of ID, parental consent form for under 18's, boots and the full team. Any teams not present with all of the above will be sent away and need to queue again when all the above are present.**

**Marks:**

**Awards:**

Ladies

Men's

**Rules:**

#### **1. ELIGIBILITY**

Note the weighing in procedure and weight bonus overleaf for the inclusion of female pullers. There is no limit on the number of males or number of females in the team (may be all male, all female or any combination of male and female).

**Coaches and Trainers** – Only one Coach is permitted with each team during pulling. Only one Trainer or "Water-Carrier" is permitted with each team. During pulling the Trainer shall take up position well clear of both teams and is not permitted to address any remark to them during actual pulling. Neither the Coach nor Trainer need comply with other rules of eligibility.

Competitors are required *in person* to produce on the day of the competition their current and signed Membership Card, with suitable photograph, or a fine of **£20** will be imposed for non-production.

#### **2. WEIGHING-IN PROCEDURE AND WEIGHT LIMITS**

The 8 member of the team will be weighed as one and will not exceed:

680kg - Men

**560kg – Ladies** *(This is reduced from 580 as in previous years)*

The competitors will be stamped or marked on a limb in a position easily seen by the Judge, but not easily erased by the rope or competitors clothing.

**At weigh-in all team members must have their boots available for inspection by the judges.**

#### **3. PULLING**

Each team shall pull a match of 2 ends against every other team in the league with points awarded as follows:

- 3 points to the winners in a straight pull (two straight pulls)
- Nil points to the losers in a straight pull
- 1 point to each team winning 1 pull each

If there is one league; the top 4 teams on points shall enter the semi-final competition as follows: 1<sup>st</sup> v 4<sup>th</sup>; 2<sup>nd</sup> v 3<sup>rd</sup>

If there are two leagues; the top 2 teams on points from each league shall enter the semi-final competition as follows: League one winner v League two runner up League two winner v League one runner up

The losers of the semi-finals shall pull off for 3<sup>rd</sup> and 4<sup>th</sup> places before the winners of the semi-finals pull off for 1<sup>st</sup> and 2<sup>nd</sup> places.

**The semi-finals, 3<sup>rd</sup>/4<sup>th</sup> pull off and the final matches shall be won by two (2) pulls out of three (3).**

If teams are drawing on points at the end of the league; they shall be ranked using the following system:

**Results of matches (between the teams drawing on points).**

**Matches won (most matches won).**

**Cautions (least number throughout pulling).**

**Team weight (lowest team weight at weigh in).**

**Coin toss or draw.**

#### 4. SUBSTITUTION

After a team has pulled the first end of the first match, the team is able to use a substitution. A substitute may replace any one puller for the duration of the competition (Age restriction of team still applies). After the substitution has taken place, no other such changes may occur. Substitution may be used for tactical reasons or due to injury.

The substitute must have been signed in with the team at weigh in and have been stamped with a mark. **All substitutes must have been members of the county at the time of the County Final;** and produced their current, signed Membership Card, with suitable photograph, or a fine of £20 will be imposed for non-production.

At the time of substitution; both, the puller to be replaced and the substitute, must report in full pulling outfit, (shirts, shorts, stockings and footwear) to the Chief Judge/Chief Steward who may designate an official to deal with the substitutes. A small (bathroom type) scale must be available at the pulling area, (in a suitable place, on solid surface), to determine the weight difference between the two pullers. The substitute puller must be of equal weight or less than the puller he/she replaces. Directly after the change, the Chief Judge or designated official shall cancel the stamp or marking of the replaced puller, and indicate a similar marking on the substitute, with an indelible marker. This change shall then be recorded.

5. **BOOTS AND SHOES – Competitors' boots must not be "faked" in any way, i.e. THE SOLE HEEL AND SIDE OF THE HEEL SHALL BE PERFECTLY FLUSH – THIS MEANS THE SOLES MUST BE SMOOTH.** No metal toecaps or metal toe-plates are permitted. Metal heel tips that are flush on the side and the bottom of the heel are permitted – this means that tips on the bottom of the heel must be smooth. If teams do not adhere to this they will be disqualified. See example below:

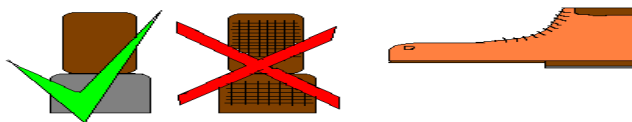

6. **ROPE** - The rope shall not be less than 4" and not more than 5" in circumference (10 cm minimum, 12½ cm maximum) without knots or other holding for the hands and the minimum length not less than 35 yards (32 metres).

7. **ROPE MARKINGS** - Five tapes or markings shall be affixed to the rope as follows: -  
i) A red tape or marking at the centre of the rope, which will be level with the ground mark at the start of every pull.

- ii) Two white tapes or markings each 4 metres either side of the red centre tape or marking
  - iii) Two blue tapes or markings each 5 metres either side of the red centre tape or marking.
- The first puller in each team shall grip the rope within 30 cm of these outer blue tapes or markings.

The white and two outer coloured markings shall be capable of easy adjustment by the Judge in the event of the rope shrinking or stretching.

8. **GROUND MARKINGS** - One line shall be marked on the ground at right angles to where the centre of the rope will be at the start of the competitions.
9. **KNOTS OR LOOPS** - No knots or loops may be made in the rope nor may it be locked across any part of the body by any member of a team. Crossing the rope over itself constitutes a loop.
10. **LOCKS** - From the start the rope shall be taut. Every pulling member shall hold the rope with both hands by the ordinary grip and the rope shall pass under the armpit. Any other hold, which prevents the free movement of the rope, is a lock and is an infringement of the Rules.
11. **ANCHOR-MAN'S GRIP**
- i) Upon taking up position the anchorman will place the rope around his/her body in the approved manner for the inspection of the Judge or his assistant.
  - ii) The approved manner will be:  
The rope will pass under one armpit diagonally across the back and over the opposite shoulder from rear to front. The remaining rope shall pass in a backward and outward direction and the slack shall run free. He/she shall grip the standing part of the rope with both arms extended forward.
12. **THE START** - When the Judge has received the sign from the two coaches that all is ready, he shall give the teams the following verbal commands:
- **'Pick up the Rope'** - at the same time extending his arms forward and horizontally. The rope shall be held as defined in paragraphs 16 and 17, the feet being flat on the ground.
  - **'Take the Strain'** - at the same time raising both hands above the head (sufficient strain shall be put on the rope to ensure that it is taut and each man may establish one foothold with the heel or side of the boot of the extended foot) - and when the rope is steady with the centre mark over the centre line on the ground - **PULL** - at the same time flinging both arms downwards.
13. **LEAVING GO OF THE ROPE** - In the event of both teams leaving go the rope before a side tape has been pulled over the side ground farthest from it, **'No Pull'** shall be declared and the pull shall not constitute on the requisite on that heat.
14. **WINNING A PULL** - A 'Pull' shall be won when one of the side markings on the rope is pulled over the centre line.
15. **FINISH A PULL** - The finish of a pull shall be signalled by the Judge blowing a whistle and pointing in the direction of the team winning the Pull.
16. **THE JUDGE** - There shall be one Judge who shall have sole control with power to appoint assistants. He shall be responsible for the Rules of the Competition being adhered to. He has the power to: grant reasonable rest periods between pulls and a minimum of six minutes rest to each team between rounds of any competition. To award 'No Pull' in the event of both teams being guilty of infringement (in such cases the pull will be re-taken immediately with no rest period or welfare to competitors being permitted) and to disqualify a team or teams after caution, or disqualify without caution for any offence against the Rules. In the event of a team being disqualified the pull will be awarded to the opposite side.

**NOTE** A team will be deemed guilty of any infringement even though only one member offends. Should it be necessary to caution a team for any infringement of the Rules, the Judge shall, in addition to naming the team and calling 'first caution' or 'last caution' also signal such caution by raising his arm to the horizontal position and pointing in the direction of the offenders. Only two

official cautions shall be given during any one pull. Any team guilty of any offence meriting a caution after already having received two official cautions in any one pull will be disqualified.

**17. INFRINGEMENT DURING CONTESTS**

- **Sitting** - deliberately sitting on the ground, or failure to return immediately to the pulling position.
- **Leaning** - touching the ground with any part of the body other than the feet.
- **Locking the Rope** - no knots or loops shall be made in the rope, nor shall it be locked across any part of the body or any member of the team. Crossing the rope over itself constitutes a loop.
- **Grip** - any grip other than the ordinary grip as described above.
- **Propping** - holding the rope in a position where it does not pass between the body and the upper part of the arm.
- **Position** - sitting on a foot or limb or the feet not extended forward of the knee.
- **Climbing the rope** - passing the rope through the hands
- **Rowing** - repeatedly sitting on the ground whilst the feet are moved backwards.
- **Anchor Man's Grip** - any grip other than described in above.
- **Footholds** - making indents in the ground in any way before the command "Take the Strain" is given. Thus cleaning the ground by foot or hand is prohibited.

**18. BEHAVIOUR** - There shall be no conduct by word or act likely to bring the sport into disrepute. No member of a team, i.e. coach, trainer or puller, may address any remark to the Judge whilst pulling is in progress. The use of water, for any purpose, is prohibited within the immediate vicinity of the rope. The function of the trainer is to attend to the requirements of the team before, between, and after pulls; he must not speak to his team during a pull. Assistant Judges shall at all times act under the direction of the Judge and shall be responsible to him for inspection of competitors' footwear, checking the ground and rope markings, the laying out of the rope before a competition and its re-alignment after each pull. During actual pulling, each Assistant Judge shall be in a position alongside the competing teams on the opposite side of the rope to the Judge. An Assistant Judge shall not address any remark to the coach or any member of the team unless he is signaled to do so by the Judge. In the event of the Judge signals a caution, the Assistant Judge shall inform the offenders, naming the team and adding 'first caution' or 'last caution'. Any instructions of the Judge conveyed by the Assistant Judge to a team must be clear and brief.

**19.** The Winner of the West Midland Area Eliminator will go on to the National Final.

## Class 46 - Cake Decorating – Intermediate

**Date/Time:** Saturday 25th May 2019.  
Booking in at **10.15am** ready to start at **10.30am**.

**Entries:** Each Club can make one entry in this competition. Competitors must be **21 years of age** or under on 1<sup>st</sup> September 2018. **Competitors Will Be Required To Show Their Current Membership Cards.**

**Marks:** Maximum of 100 marks towards the SHOW CHAMPIONSHIP CUP.  
Maximum of 100 marks towards the VENABLES SHIELD.  
Maximum of 100 marks towards the JUBLIEE CUP.

**Rules:**

1. Maximum time allowed **ONE HOUR**.
2. Each competitor is required to decorate a cake (or dummy), which has been covered with **FONDANT ICING** prior to the competition (with no other decoration added), to the theme of **“Easter Cake”**.
3. The size of the cake board must not exceed **14"** (at its widest point) and can be of any shape. **NOTE: boards sold as 14" will measure more at their diagonal.** Competitors are strongly advised to check their boards, as they may not have been measured at their County Rally/Show.
4. Decorative work may include royal icing, handmade piped or modelled sugar craft flowers, run outs and ribbons. Non-edible items to be used with discretion.
5. The cake must not exceed two tiers.
6. Competitors are reminded the cake must be suitable for a family audience.
7. Judges will give credit for skill and techniques of decorations used.
8. Judges may require competitors to make samples of decorations used.
9. Royal icing may be made prior to the competition.
10. The following scale of marking will be observed:

Decoration	20
Craftsmanship (E.g. skill in piping)	40
Originality and Creativity	10
Suitability of design and relevance to the theme	10
Overall Presentation and Finish	20
<b>Total</b>	<b>100</b>

11. Competitors will be required to bring all their own equipment and ingredients, including hot water. Icing may be brought ready mixed.
12. No names of clubs or counties to be marked on any exhibits.
13. Competitors must wear clean white coats during the competition.
14. No exhibits in any competition may be removed before the presentation on Saturday 25th May 2019, unless otherwise directed by the Chief Steward. Failure to comply will result in all marks awarded for the competition concerned being removed and the competitors disqualified.

## Class 47 - YFC's Got Talent

**Date/Time:** Saturday 25th May 2019.  
Booking in **10.15am** to start at **10.30am**.

**Entries:** Each Club can make one entry in this competition. An entry consists of a team of Minimum of **TWO** and **FIVE** Members in this competition. Competitors must be **26 years of age or under** on 1<sup>st</sup> September 2018. **Competitors Will Be Required To Show Their Current Membership Cards.**

**Marks:** Maximum of 100 marks towards the SHOW CHAMPIONSHIP CUP.

**Rules:**

1. Teams to perform an act - **“YFC’s Got Talent”**. Competitors to provide their own equipment.
2. A carpeted staged area of 6m x 6m and 2.5m high and set 1 foot off the ground approximately, will be provided for the display.
3. A PA System, up to 5 handheld microphones will be provided. Backing Music allowed. Competitors to supply any instruments or musical effects as desired.
4. Time allowed will be **FIVE MINUTES maximum** and **TWO MINUTES minimum**. Time penalties of one mark per thirty seconds or part thereof above this time. This does not include setting and dismantling of stage.
5. The following marking scale will be observed:

Creativity of the performance	50
Variety	25
Overall Effect	25
<b>Total per team</b>	<b>100</b>

## **Class 48 - Cake Decorating – Junior**

<b>Date/Time:</b>	Saturday 25th May 2019.
	Book in <b>9.15am</b> ready to start at <b>9.30am</b> .
<b>Entries:</b>	Each Club can make one entry in this competition. Competitors must be <b>16 years of age or under</b> on 1 <sup>st</sup> September 2018. <b>Competitors Will Be Required To Show Their Current Membership Cards.</b>
<b>Marks:</b>	Maximum of 100 marks towards the SHOW CHAMPIONSHIP CUP
	Maximum of 100 marks towards the JUNIOR EVENTS CUP.
	Maximum of 100 marks towards the VENABLES SHIELD.

### **Rules:**

1. Maximum time allowed **ONE HOUR**.
2. Each competitor is required to decorate 6 cup cakes (or dummies), which has been covered with **ICING** prior to the competition (with no other decoration added), to the theme **“Under The Sea”**.
3. The size of the cupcake display area must not exceed **14"** (at its widest point) and can be of any shape. **NOTE: boards sold as 14" will measure more at their diagonal.** Competitors are strongly advised to check their boards, as they may not have been measured at their County Rally/Show.
4. Decorative work may include royal icing, handmade piped or modelled sugar craft flowers, run outs and ribbons. Non-edible items to be used with discretion.
5. Competitors are reminded the cupcakes must be suitable for a family audience.
6. Judges will give credit for skill and techniques of decorations used.
7. Judges may require competitors to make samples of decorations used.
8. Royal icing may be made prior to the competition.
9. The following scale of marking will be observed:

Decoration	20
Craftsmanship (E.g. skill in piping)	40
Originality and Creativity	10
Suitability of design and relevance to the theme	10
Overall Presentation and Finish	20
<b>Total</b>	<b>100</b>
10. Competitors will be required to bring all their own equipment and ingredients, including hot water. Icing may be brought ready mixed.
11. No names of clubs or counties to be marked on any exhibits.
12. Competitors must wear clean white coats during the competition.
13. No exhibits in any competition may be removed before the presentation on Saturday 25th May 2019, unless otherwise directed by the Chief Steward. Failure to comply will result in all marks awarded for the competition concerned being removed and the competitors disqualified.



## Class 49 - Haka

**Date/Time:** Saturday 25th May 2019.  
Booking in at **14.15pm** ready to start at **14.30pm**.

**Entries:** Each Club can make one entry in this competition. An entry consists of a **team of minimum of TWO and maximum of SIX members**. Competitors must be 26 years of age or under on 1<sup>st</sup> September 2018. **Competitors Will Be Required To Show Their Current Membership.**

**Marks:** Maximum of 100 marks towards the SHOW CHAMPIONSHIP CUP.  
Maximum of 100 marks towards the AFTERNOON EVENTS CUP.

**Rules:**

1. Teams to perform a **“HAKA”** Competitors to provide their own equipment.
2. A carpeted **staged** area of **6m x 6m and 2.5m high and set 1 foot off the ground approximately**, will be provided for the display.
3. Time allowed will be **FIVE MINUTES maximum and TWO MINUTES minimum**. Time penalties of one mark per thirty seconds or part thereof above this time. This does not include setting and dismantling of stage.
4. The following marking scale will be observed:

Creativity of the Haka	50
Vocal ability & Rhythmic Interpretation	25
Presentation & Costume	25
<b>Total per team</b>	<b>100</b>

## Class 50 - Cake Decorating – Senior

**Date/Time:** Saturday 25th May 2019.  
Booking in at **12.15pm** ready to start at **12.30pm**.

**Entries:** Each Club can make one entry in this competition. Competitors must be **26 years of age or under** on 1<sup>st</sup> September 2018. **Competitors Will Be Required To Show Their Current Membership Cards.**

**Marks:** Maximum of 100 marks towards the SHOW CHAMPIONSHIP CUP.  
Maximum of 100 marks towards the VENABLES SHIELD.  
Maximum of 100 marks towards the JUBLIEE CUP.

**Rules:**

1. Maximum time allowed **ONE HOUR**.
2. Each competitor is required to decorate a cake (or dummy), which has been covered with **FONDANT ICING** prior to the competition (with no other decoration added), to the theme **“Life on the Slopes”**.
3. The size of the cake board must not exceed **14”** (at its widest point) and can be of any shape. **NOTE: boards sold as 14” will measure more at their diagonal.** Competitors are strongly advised to check their boards, as they may not have been measured at their County Rally/Show.
4. Decorative work may include royal icing, handmade piped or modelled sugar craft flowers, run outs and ribbons. Non-edible items to be used with discretion.
5. Competitors will have two gas rings available to use if they so desire.
6. Competitors are reminded the cake must be suitable for a family audience.
7. Judges will give credit for skill and techniques of decorations used.
8. Judges may require competitors to make samples of decorations used.
9. Royal icing may be made prior to the competition.
10. The following scale of marking will be observed:

Decoration	20
Craftsmanship (E.g. skill in piping)	40
Originality and Creativity	10
Suitability of design and relevance to the theme	10
Overall Presentation and Finish	20
<b>Total</b>	<b>100</b>

11. Competitors will be required to bring all their own equipment and ingredients, including hot water. Icing may be brought ready mixed.
12. No names of clubs or counties to be marked on any exhibits.
13. Competitors must wear clean white coats during the competition.
14. No exhibits in any competition may be removed before the prize giving on Saturday 25th May 2019, unless otherwise directed by the Chief Steward. Failure to comply will result in all marks awarded for the competition concerned being removed and the competitors disqualified.

## Class 51 - Sand Castle Building

**Date/Time:** Saturday 25th May 2019.  
Booking in at **14.15pm** ready to start at **14.30pm**.

**Entries:** Each Club can make one entry in this competition. An entry consists of a **team of a of TWO members**. Competitors must be 26 years of age or under on 1<sup>st</sup> September 2018. **Competitors Will Be Required To Show Their Current Membership Cards.**

**Marks:** Maximum of 100 marks towards the SHOW CHAMPIONSHIP CUP.  
Maximum of 100 marks towards the AFTERNOON EVENTS CUP.

### **Rules:**

1. Team **“Sand Castle Building”** incorporating the holiday theme within the time allocated. To design and construct a sand castle as competitor's choice.
2. The area will be a **grassed area of approximately 1m x 1m**.
3. Competitors to provide their own sand and accessories. Finished sand castles to be displayed.
4. Time allowed will be **Twenty minutes maximum**.
5. Area should be kept clean using tarpaulin or sheet provided by the competitors
6. Competitors that are over or under the allotted time will be penalised by the deduction of 1 mark for every 1 minute or part thereof over/under time.
7. The following scale of marking will be observed:

Construction	25
Design	25
Originality	25
Overall Effect	25
<b>Total</b>	<b>100</b>

## Class 52 - Chairman's Challenge

**Date/Time:** Saturday 25th May 2019.  
Booking in at 9.30am ready to start at **9.45am** and times to be allocated.

**Entries:** Each Club can make one entry in this competition. An entry consists of **TWO** members per team **ONE 26 and under** on 1<sup>st</sup> September 2018 and **ONE 21 and under** on 1<sup>st</sup> September 2018. **Competitors Will Be Required To Show Their Current Membership Cards.**

**Associate members are welcome to take part at there own risk.**

**Marks:** Maximum of 100 marks towards the SHOW CHAMPIONSHIP CUP.

**Rules:**

1. Time allowed will be up to **30 MINUTES.**
2. All materials required will be supplied.
3. Competitors will be required to perform a task set by the **Rally Chairman** on the day of the competition.
4. Competitors should be aware that the competition could take any form: this may involve getting dirty or wet. Competitors should bring a change of clothes if they wish.
5. The following scale of marks will be observed:

First placed team	100
Second placed team	90
Third placed team	80
Fourth placed team	70
Fifth placed team	60
Sixth placed team	50

## Class 53 - Poultry Boning & Jointing

**Date/Time:** Saturday 25th May 2019.  
Booking in at **8.30am** ready to start at **8.45am**.

**Entries:** Each County may **make ONE entry of TWO competitors** in this competition. **TWO** competitors must be **26 years of age or under** on 1<sup>st</sup> September 2018. **Competitors Will Be Required To Show Their Current Membership Cards.**

**Marks:** Maximum of 200 marks towards the SHOW CHAMPIONSHIP CUP.  
Maximum of 200 marks towards the VENABLES SHIELD.  
Maximum of 200 marks towards the Poultry Cup.

**Rules:**

1. Time allowed will be **THIRTY MINUTES** for boning and stuffing the bird and **TWENTY MINUTES** for jointing. Competitors taking over that time will be penalised at a rate of one mark for every thirty seconds or part thereof.
2. Each competitor will be required to Bone and Stuff one **trussed** bird and a second **trussed** bird is to be jointed and packed for the freezer. Competitors are to bring their **trussed** birds as bought from the butchers/supermarket with the giblets removed and not to cut anything off the chickens before the competition. The two **trussed** birds that competitors provide must each weigh between 1.6kg to 2.0kg.
3.
  - a) **Procedure - Boning:** - Competitors will be required to bone the trussed chicken, stuff and display. Competitors to provide their own stuffing, which may be made beforehand, and the carcass to be displayed.
  - b) **Procedure - Jointing:** - Competitors will be required to remove the wishbone and display, remove both legs and divide into two (4 joints); remove both wings, taking away a little of the breast meat; remove the two breast joints and display joints suitably packed for deep freezing. Carcass to be displayed.
4. The use of newspaper is NOT permitted and any greaseproof paper used must NOT be removed from the table during the competition until directed by the Judge or Steward.
5. The following scale of marking will be observed:

	<b>Boning</b>	<b>Jointing</b>	
Preparation of table	5	5	
Cleanliness of carcass	10	10	
Labelling and Packing	5	5	
Tying and stuffing	10	-	
Joints of Even Size	-	10	
Overall Cleanliness	10	10	
Finished appearance	10	10	
<b>Total per competitor</b>	<b>50</b>	<b>50</b>	<b>100</b>

6. Competitors must wear clean white coats and suitable headwear during the competition
7. Birds will be removed by stewards after judging on the day of the competition. Comment cards will be displayed for the remainder of the show.
8. No comment cards may be removed before the prize giving on Saturday 25th May 2019, unless otherwise directed by the Chief Steward. Failure to comply will result in all marks awarded for the competition concerned being removed and the competitors disqualified.

## Class 54 - Carnival Dance

**Date/Time:** Saturday 25th May 2019.  
Booking in at **13.45** ready to start at **14.00pm**.

**Entries:** Each Club can make one entry in this competition. An entry consists of a team of **SIX** members. Competitors must be **26 years of age or under** on 1<sup>st</sup> September 2018. **Competitors Will Be Required To Show Their Current Membership Cards.**

**Marks:** Maximum of 100 marks towards the SHOW CHAMPIONSHIP CUP.  
Maximum of 100 marks towards the AFTERNOON EVENTS CUP.

### **Rules:**

1. Teams will be required to perform a **“Carnival Dance”**.
2. The size of the dance area will be a **staged area 6m x 6m**.
3. For completion of the dance teams have a **MAXIMUM of five minutes and a MINIMUM of two minutes**.
4. Under no circumstances must any team use overhead lifts/tumbling, pyramids, throws or any other move that should jeopardise the safety of themselves or others
5. Stage time not to exceed **TEN minutes** in duration. This includes setting and dismantling of the stage. Time penalties of one mark per thirty seconds or part thereof above this time. This does not include setting and dismantling of stage.
6. The following scale of marking will be observed:

Variety	30
Technical Marks	30
Costume	20
Overall Presentation	20
Total	100

## Class 55 - Tractor Handling & Maintenance

Time: **09:15am** booking in and time slot allocation starting from **09:30am**.

Entries: Competition is open to one member from each Club in the County.  
Member to be **26 years of age or under** on 1st September 2018, but over 17 years of age on show day. **Competitors will be required to show their current membership cards and driving/tractor licence when booking in.**

Marks: Max 100 towards the Show Championship Cup.  
Max 100 towards the Amoco Tractor Handling Tankard.  
Max 100 towards the Jubilee Cup.

### Rules

- 1 Competitors to demonstrate their competence and ability in tractor handling by driving a tractor as directed around a course set by the judge. Questions will also be asked on maintenance of the machinery.
- 2 Dangerous or reckless driving will be penalised at the Judge's discretion and under certain circumstances will stop the driver if it is felt the driving is dangerous.
- 3 Competitors must hold and produce for inspection either a Full UK Driving Licence or Tractor Licence
- 4 The decision of the judge will be final.
- 5 The Show General Rules apply to this competition – Please Read them – Front of Rule Schedule.
- 6 During the period of the Competition, Competitors must not communicate directly or indirectly with any person other than Judges or Stewards under penalty of disqualification, this includes the use of any telecommunication device.

Marking:	This Competition will be marked out of 100 points.
<b>Total</b>	<b>100</b>

## Class 56 – Four Wheel Drive Handling & Maintenance

- Time: **09:15am** booking in and time slot allocation from **09:30am**.
- Entries: Competition is open to one member from each Club in the County. Member to be **26 years of age or under** on 1st September 2018, but over 17 years of age on show day. **Competitors will be required to show their current membership cards and a valid UK driving licence when booking in.**
- Marks: Max 100 towards the Show Championship Cup.  
Max 100 towards the Jubilee Cup.
- Rules:
- 1 Competitors to demonstrate their competence and ability in 4x4 handling by driving vehicle and trailer as directed around a course set by the judge. Questions will also be asked on mechanical and electrical maintenance of the vehicle.
  - 2 Dangerous or reckless driving will be penalised at the Judge's discretion and under certain circumstances will stop the driver if it is felt the driving is dangerous.
  - 3 Competitors must hold and produce for inspection a Full UK Driving License.
  - 4 The Show General Rules apply to this competition – Please Read them – Front of Rule Schedule.
  - 5 Competitors must be 17 years of age or over.
  - 6 Valuable articles are the responsibility of the exhibitors.
  - 7 The decision of the judge will be final.
  - 8 During the period of the Competition, Competitors must not communicate directly or indirectly with any person other than Judges or Stewards under penalty of disqualification, this includes the use of any telecommunication device.
  - 9 No alcohol is to be consumed by any competitor either before or during the competition; infringement of this rule will result in disqualification.



## Class 57 –ATV Handling & Maintenance

- Time: **09:15am** booking in and time slot allocation starting from **9:30am**.
- Entries: Competition is open to one team of two members from each Club in the County. One member of each team to be **between 16 years of age and 26 years of age** on 1st September 2018, and one to be 21 years of age or under of the 1st September 2017. **Competitors must have attained their 16th birthday before Show Day.**
- Marks: Max 300 towards the Show Championship Cup.  
Max 300 towards the Mike Greaves Tankard ATV Challenge Cup.
- Rules:
- 1 The Show General Rules apply to this competition – Please Read them – Front of Rule Schedule
  - 2 Competitors will be required to show their current valid (photo & signed) 18/19 membership card or a Temporary card issued by the show office valid for Show Day.
  - 3 Competitors must hold and produce for inspection a certificate in competence in ATV Handling. At least one member of the team must hold a current first aid certificate of the British Red Cross, St John Ambulance or an alternative nationally recognised body. A copy of the ATV Competency and First Aid certificate must be handed into Jo at the Office no later than 11th May 2019. These certificates must also be brought on the date of the competition to be shown to the Judge.  
Competitors must provide and wear head protection, which protects the head and neck, and that are to British Standards at the time of the competition.
  - 4 In the absence of any of the above the competitor will not be allowed to compete.
  - 5 Team members will not be allowed to assist each other during the competition.
- Procedure:
- 6 Task 1- Both team members are required to carry out daily maintenance and safety checks on the ATV prior to commencing the tasks. Competitors to carry out a verbal risk assessment with the judge on relevant part of the tasks that they will be completing. This section will be timed 10 minutes.  
Task 2 – One competitor will be required to drive an ATV through a 'set' course, negotiating various obstacles and terrain. He/ she will also be required to reverse the ATV through one part of that same course, maneuvering the ATV to a set point where the trailer is ready to be hitched.  
Task 3 – Both team members, working together, are required to hitch the trailer, correctly load and secure the load onto the trailer as directed by the judge. For this task only the two competitors can assist each other.  
Task 4 – The other competitor will drive forwards through the same set course with the loaded trailer, manoeuvre that trailer through various obstacles and reverse into 'set garages'. The 15 minutes time limit will only commence when the second competitor begins his/her section of the driving.  
Marks will be deducted if either the ATV or trailer hits any set obstacles. The number of attempts at each obstacle will also be taken into consideration. The emphasis of the competition will be on skill, balance and safe operation of the machine.
  - 7 First- Aid Task – Between tasks 2 & 3 a mock ATV accident will be staged. The stewards will announce to the competitors when the accident happens; the two team members are to work together to deal with the situation. A First Aid kit will be provided.  
It is expected that there will be by-standers who may be questioned regarding the accident.  
  
The First Aid Judge will indicate when the casualty has been satisfactorily dealt with and when the member or members may recommence work.  
Knowledge of elementary First Aid is necessary, but in no case will competitors be expected to render assistance further than instructed in the Joint First Aid Manual of

St John's Ambulance and The Red Cross (available from WH Smith or good large bookshops).

- 8 Time allowed: The competitors will be allowed 10 minutes for the safety checks and verbal risk assessment with the judge.  
Task 1 – First competitor will be allowed 10 minutes to complete the course.  
Task 2 – Loading & hitching of the trailer is not timed – emphasis is on safe operating procedures.  
Task 3 – Second competitor will be allowed 15 minutes to complete the course.  
Task 4 - One mark per minute or part thereof will be deducted for over time.
- 9 Dangerous or reckless driving will be penalised at the Judges discretion and under certain circumstances will stop the driver if it is felt the driving is dangerous.
- 10 The decision of the judge will be final.
- 11 During the period of the Competition, Competitors must not communicate directly or indirectly with any person other than Judges or Stewards under penalty of disqualification, this includes the use of any telecommunication device.

Marking:

The following scale of marks will be observed

Task 1	A – Safety Checks	50
	B – Verbal Risk Assessment (Suitability & Completeness)	50
Task 2	First Competitor driving ATV	50
Task 3	Hitching Trailer	50
Task 4	Second Competitor driving ATV & Trailer	50
First Aid	First Aid Task (Only applies if team finish within the time limit)	50
	<hr/>	
	Total	<hr/> 300